



Manual Revision 4.0
December 1, 1999

Copyright and Trademark Notices

Copyright ©Verisys, Inc. 1992, 1993, 1994, 1995, 1996, 1997, 1998, 1999. All rights reserved. No part of this publication may be reproduced, stored in a retrieval system or transmitted, in any form or by any means, electronic, mechanical photocopying, recording or otherwise, without the prior consent of Verisys, Inc., 335-H Spreckels Dr., Aptos, CA 95003, Voice: (831) 662-7900, FAX: (831) 662-7910. (*Individual photocopies for a Verisys customer use is allowed.*)

Verisys™ and SCSI-View™ are trademarks of Verisys, Inc.

Any other trademarked names mentioned in this manual are the property of their respective owners.

The material in this manual is for information only and is subject to change without notice.

FCC Regulations:

This equipment is intended for industrial/commercial application. Therefore, it is excluded from FCC Class B, Part 15 regulations.

Technical Support

If you experience any problems with SCSI-View, please call us. Our Technical Support Group is available Monday through Friday, 8:00am to 5:00pm, Pacific Coast Time.

Technical Support can be reached at (831) 662-7900, FAX (831) 662-7910

svsupport@verisys.com and <http://www.verisys.com>

Comments and Suggestions

Verisys is very interested in any comments or suggestions that you may have regarding SCSI-View. Verisys is continually adding new analysis features to the product and are always looking for new ways to address customer needs. Please contact our Technical Support Group at the above numbers.

Table of Contents

1	Where to Go Next	9
2	Conventions used in this Manual	11
2.1	User Entries	11
2.2	Menu Navigation Instructions	11
3	Introduction	13
3.1	What is SCSI-View™?	13
3.2	SCSI-View Features (a quick overview)	17
3.2.1	SCSI Capture Operation	18
3.2.2	Performance Analysis	19
3.2.3	Protocol Analysis	21
3.2.4	Timing View	22
3.2.5	SCSI Search Capabilities	23
3.2.6	Popup Menu Operations	25
3.2.7	LED Indicators	26
3.3	Summary	26
4	SCSI-View Installation	29
4.1	INTRODUCTION	31
4.2	COMPUTER PLATFORM REQUIREMENTS	31
4.2.1	NOTEBOOK PCMCIA SETUP CONSIDERATIONS	31
4.2.2	Using the SCSI-View on ISA Bus Platforms (SV-ISA)	32
4.3	SCSI-VIEW COMPONENTS and FILES	32
4.3.1	SCSI-View Software Installation (SV-8160 / SV-3000 / SV-1620) 33	
4.3.2	SCSI-VIEW Driver Installation	35
4.4	CHECK FOR PROPER HARDWARE INSTALLATION on WIN 95/98/2000	36
4.5	PROGRAM INSTALLATION INSTRUCTIONS	36
4.5.1	Reboot Windows and start SCSI-View	36
4.5.2	PCMCIA-02 Card Upgrade	37
4.5.3	SCSI-View Uninstall	37
4.6	Connecting SCSI-View to your SCSI system	38
4.6.1	SCSI Bus Termination	38

4.7	Resolving SCSI-View Problems	41
4.7.1	No Hardware Detected.....	41
4.7.2	SCSI-View Pod not detected; SCSI-View cannot start	43
4.7.3	No interrupts; SCSI-View Fails to Capture	44
4.7.4	Memory and Buffer Allocation Issues.....	47
5	Quick Start - Analyze SCSI Activity.....	49
5.1	SCSI-View Quick Start Summary	51
5.2	Starting SCSI-View.....	53
5.3	Starting and Stopping SCSI Capture (Alt-C).....	54
5.4	The SCSI Command and Phase Views.....	57
5.5	Moving Around Analysis Views.....	59
5.6	Searching Protocol Capture Files.....	61
5.7	Filtering Views for Specific Device ID's and LUN's.....	64
5.8	The Performance View	65
5.9	On line HELP (F1)	66
5.10	Exiting SCSI-View (ALT-X).....	66
6	Detailed Feature Descriptions.....	67
6.1	Protocol Analysis.....	69
6.1.1	Phase View.....	69
6.1.2	Linked Phase and Timing Views	74
6.1.3	Command View	75
6.1.4	Linked Command Views and Phase Views	79
6.1.5	Filtering Protocol Views by ID and LUN	81
6.1.6	Searching Command and Phase Views	82
6.1.7	Setting and Using Markers	87
6.2	Performance Analysis.....	89
6.2.1	Performance Analysis Sections.....	90
6.2.2	Performance Measurements - Detailed Descriptions	91
6.2.3	Filtering Performance Views by ID and LUN	97
6.3	Timing Waveform Analysis.....	99
6.3.1	Normal and Recirculate Capture (SV-8160 / SV-3000).....	99
6.3.2	Enabling Timing Capture Mode (SV-1620 / SV-1600)	100
6.3.3	Capture Options for Timing	101
6.3.4	Timing View	103
6.3.5	Timing Popup Operations.....	104

6.3.6	Linked Phase - Timing Views	110
6.3.7	In Case of Problems	111
6.4	Bus Inspector View.....	113
6.5	LED Indicators.....	114
6.5.1	ANALYZER STATUS LED	114
6.5.2	SCSI STATUS LED.....	114
7	Command and Menu Reference	115
7.1	The MAIN SCSI-View Screen.....	119
7.2	FILE	121
7.2.1	SCSI Capture Beg / End.....	121
7.2.2	Load Defaults	122
7.2.3	Save Defaults	122
7.2.4	Change Data Directory	122
7.2.5	Change Export/Print Directory	122
7.2.6	Change File Session Name	123
7.2.7	Delete Session File	123
7.2.8	Information	123
7.2.9	Hardware Information	124
7.2.10	Export	124
7.2.11	Extract	125
7.2.12	Print (Prints the active View)	125
7.2.13	Exit.....	126
7.2.14	Unattended Capture with Pod Disconnected	126
7.3	OPTIONS	129
7.3.1	Hardware	129
7.3.2	Color Palette	130
7.3.3	Load Palette	130
7.3.4	Popup Operations	131
7.3.5	Timing Popup Operations	147
7.3.6	Display Views	154
7.3.7	Display Units	155
7.3.8	Modify Command Strings	155
7.3.9	Define Read/Write Opcodes	156
7.3.10	Timing Display Options	157
7.3.11	Popup Display Defaults	157
7.3.12	25/50 Lines	158
7.3.13	Capture Options	158
7.3.14	Normal / Recirculate Capt Type (SV-8160 / SV-3000)	169
7.3.15	Phase / Timing Capture Mode (SV-1620 / SV-1600).....	170
7.4	ANALYSIS.....	171
7.4.1	Phase and Command Views	172

7.4.2	Performance	175
7.4.3	Bus Inspector.....	176
7.5	WINDOW	177
7.5.1	Next	177
7.5.2	Zoom.....	177
7.5.3	Close.....	177
7.5.4	Close All	177
7.5.5	Size	177
7.5.6	Move.....	178
7.5.7	Cascade.....	178
7.5.8	Tile	178
7.6	HELP	179
7.6.1	Index.....	179
7.6.2	Getting Started.....	179
7.6.3	Cursor Movement Keys	180
7.6.4	Function & Hot Keys.....	180
7.6.5	Mouse Functions	182
7.6.6	Technical Support	183
7.6.7	About	183
7.7	Miscellaneous Dialogs.....	185
7.7.1	Open File Dialog.....	185
8	SCSI-View Specifications	187
8.1	SV-8160.....	187
8.2	SV-3000.....	187
8.3	SV-1620.....	188
8.4	SV-1600.....	188
8.5	Timing Option	189
8.6	SV-8020.....	189
8.7	Software Analysis Features - All Analyzers	189
8.7.1	Protocol Analysis:	190
8.7.2	Performance Analysis: (for each SCSI ID, LUN).....	192
8.7.3	SCSI Bus Inspector View	192
8.8	SV-ISA	193
8.9	SV-HostEm	193
8.10	SCSI-View Reader	193
8.11	SV-Interface	193

9 Verisys Warranty and Repair Policy..... 194

1 Where to Go Next

SCSI-View Installation

Section 4: SCSI-View Installation on page 29.

Use SCSI-View immediately

Section 5: Quick Start - Analyze SCSI Activity, on page 49.

Get detailed descriptions of each SCSI analysis feature

Section 6: Detailed Feature Descriptions, on page 67.

Find a Specific SCSI-View Menu Command

Section 7 Command and Menu Reference on page 114.

SCSI-View has extensive context sensitive on line help.

Help includes complete descriptions of every Phase, Command and Performance View display item and 'how to use' instructions for each feature. Help includes detailed descriptions of how each performance calculation is made.

Press F1 for a complete Help description of the currently displayed analysis View or menu item. For a more structured on line description see the **Help, Index** menu item for a complete hypertext linked description of how to use SCSI-View.

2 Conventions used in this Manual

This manual assumes user familiarity with SCSI protocol, Windows 95/98, Windows NT4.0 or Windows 2000.

2.1 User Entries

All **user entries** in this manual are indicated in a **BOLD, Arial typeface**. The Enter key is indicated by the ↵ symbol. The phrase ‘type **SV**↵’ instructs the user to type the word ‘SV’, followed by the Enter key.

Unless stated otherwise, the instruction to ‘**click**’ on a particular item instructs the user to position the mouse cursor over that item and then to push the left mouse button.

The instruction ‘**to drag**’, which is used to move or re-size a window, instructs the user to place the mouse cursor over an object and to press and hold the left mouse button while moving the mouse to a new location, and then to release the left mouse button when finished.

2.2 Menu Navigation Instructions

Selection of pull down menu items is specified sequentially. The sequence ‘**select OPTIONS, COLOR PALETTE**’ instructs you to first click on the **OPTIONS** menu selection at the top of the main SCSI-View screen, and then to click on **COLOR PALETTE** from the pull down list of items.

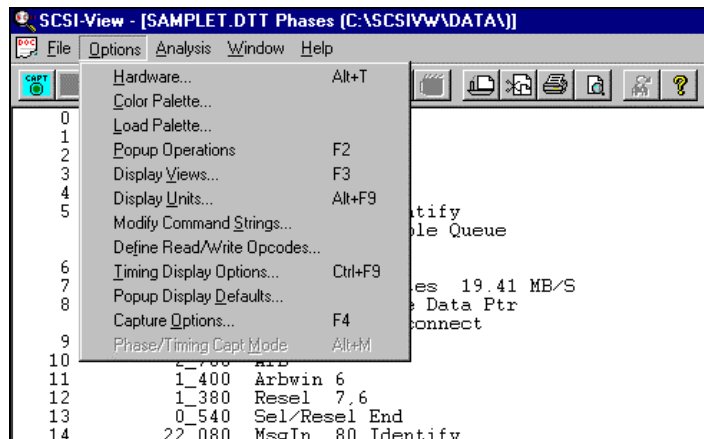

Figure 1

SCSI-View menus can also be navigated directly from the Keyboard. To select from the Main Menu, hold down the <ALT> key and type the highlighted letter of the desired category (typically the first letter). To select an item from a pull

down menu, type the highlighted letter for that item. In the previous example, the user keyboard entries would be **<ALT> O, C**.

3 Introduction

In This Chapter:

3.1	What is SCSI-View™?	13
3.2	SCSI-View Features (a quick overview)	17
3.2.1	SCSI Capture Operation.....	18
3.2.2	Performance Analysis.....	19
3.2.3	Protocol Analysis	21
3.2.4	Timing View	22
3.2.5	SCSI Search Capabilities.....	23
3.2.6	Popup Menu Operations	25
3.2.7	LED Indicators.....	26
3.3	Summary	26

3.1 What is SCSI-Viewä ?

Verisys SCSI-View analyzers are unique SCSI analysis instruments that capture, display, and analyze SCSI activity in real time. Their features include:

- Capture of Wide and Narrow SCSI activity from SCSI-1, 2 and 3 systems.
- Capture at up to Ultra3 speeds with 4ns Req-Ack accuracy (SV-8160). The SV-3000 runs at Ultra2 speeds with 5ns Req-Ack accuracy and the SV-1620 / SV-1600 run at Ultra-1 speeds with 10ns Req-Ack accuracy.
- Windows 95/98, Windows NT 4.0 or Windows 2000 interface application that runs concurrently with other applications (including SCSI stimulators).
- Selection of Single Ended or Differential SCSI bus interfaces from the same hardware.
- Optional unattended SCSI capture with the POD disconnected and powered separately from the notebook PC (SV-8160 and SV-3000 only, with supplied external power module).
- Protocol Analysis of SCSI activity that can be viewed at the Command, Phase and Timing levels. Double clicking on a line in Command or Phase View links the next lower level View (Command to Phase, Phase to Timing). Movement in the parent window is followed in the linked detail window.

- Real time Performance Analysis of SCSI activity, including: Connect and Burst Data Rates, SCSI Phase Times, Bus Utilization, R/W Command Completion Times, and Number of Disconnects per Command.
- Tagged Queuing performance analysis, including Minimum, Maximum and Average Queue Depth per ID.
- Real time display. All SCSI activity is displayed on screen as it occurs.
- Capture long SCSI protocol sessions directly to disk.
- Trigger conditions are augmented with powerful search, filter and marker tools. Extended capture sessions can be searched by Command, Message, Bus Condition, Data Phase values, Phase Time and Data Phase Burst Rate. SCSI-View eliminates the need to manually search through huge SCSI printouts.

SCSI-View provides a way for you to easily analyze SCSI bus behavior spanning large time periods--without overwhelming you with large amounts of low level SCSI protocol data. Powerful analysis tools, multiple levels of protocol display detail, searching and ID filtering capabilities isolate SCSI protocol and performance analyses find problems that were previously buried in a sea of low level detail.

SCSI-View is designed to both supplement and go beyond existing SCSI Bus, (logic), Analyzer features in a number of ways:

- **SCSI-View** can capture long periods of SCSI bus activity directly to disk and provides the user with **powerful analysis, search and display tools** to locate difficult SCSI problems.
- The SV-8160 (8 million events) and SV-3000 (2 million events) contain **large hardware capture buffers** in their pods. SCSI activity can be captured circularly to the large event buffer (including 100% of data phases), or captured to PC RAM or to a disk file
- SCSI-View is a flexible **multi-tasking system**, and can **display multiple analyses at once**.
- SCSI-View provides **performance analysis, multi-level protocol display** (linked Command, Phase and Timing Views), **powerful protocol search tools** and **tagged queuing analysis**.

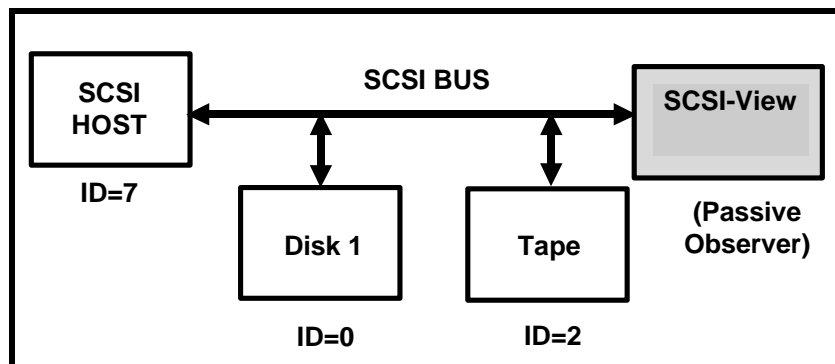

Figure 2

SCSI-View is a passive SCSI observer, and does not alter SCSI bus activity. Once it is plugged into the target SCSI bus, SCSI-View can immediately display detailed analysis information. Separate windows display SCSI performance, tagged queuing and protocol analysis as soon as SCSI activity begins. All analysis and display takes place in real time as SCSI events unfold.

Error! Reference source not found. shows a typical SCSI-View screen with **Performance, Command** and detailed **Phase Views** enabled. The user can add, delete and size multiple analysis windows at will. Windows for both the current active capture session and previous capture files can be displayed side by side on the screen.

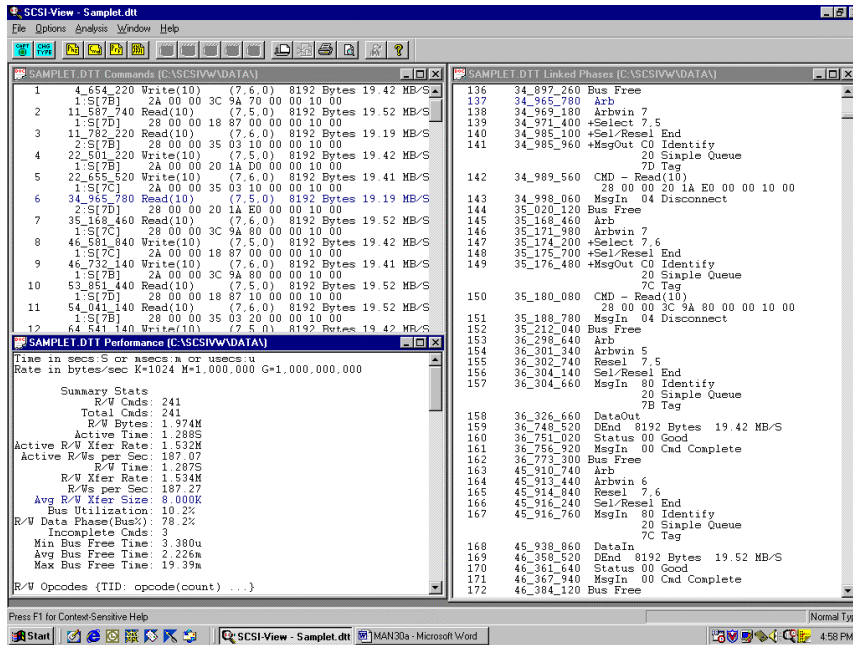

Figure 3

3.2 SCSI-View Features (a quick overview)

SCSI-View runs under Windows 95 / 98 / NT4.0 or 2000 as a multi-tasking system. While SCSI protocol is being captured to a file, any number of analysis windows can be opened, configured and manipulated by the user. Information is updated on screen as soon as new SCSI events occur.

SCSI-View is capable of displaying simultaneous SCSI Protocol, Timing and Performance analyses. **Each analysis window runs independently from the others, and can take its input either from current SCSI capture session, or from previously captured session files.** Each window can be configured for varying levels of display detail, and for which SCSI device(s) are to be analyzed.

A mouse or similar pointing device is desirable, but is not required. Keyboard cursor navigation is entirely possible via hot keys. (See section 7.6.4 on page 180.) The flexibility and speed of navigation that is gained by using a mouse (or equivalent) will be significant when active multi-View analysis is being performed.

SCSI-View has extensive context sensitive on line help.

Help includes complete descriptions of every Timing, Phase, Command and Performance View display item and 'how to use' instructions for each feature. **Press F1 for a complete Help description of the current displayed analysis View or menu item.** For a more structured on line description see the **Help, Index** menu item for a complete hypertext linked description of how to use SCSI-View.

3.2.1 SCSI Capture Operation

SCSI-View captures directly to its event buffer or to PC RAM and disk files. SCSI activity spanning hours to days can be captured, limited only by total hard disk size. All SCSI activity is always written to disk either during capture or at the end of capture.

To start capturing SCSI activity, click either on the **Capture** toolbar button, **FILE- SCSI Capture Beg/End**, or type **ALT – C** (**Error! Reference source not found.**). Repeating these actions toggles capture off.

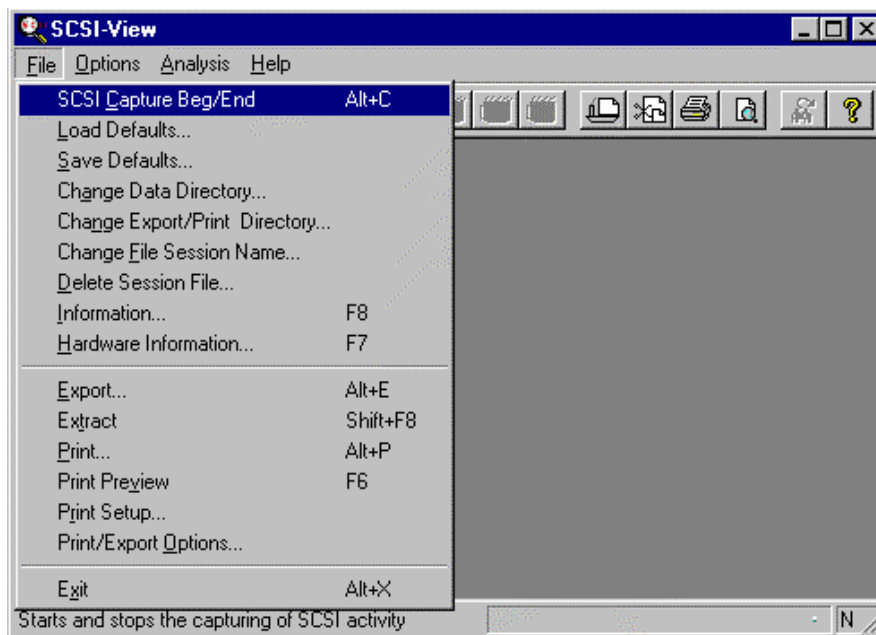

Figure 4

Capture can be performed in two modes, Normal or Recirculate (SV-8160 / SV-3000 only). Normal capture treats the Pod RAM buffer like a large FIFO and transfers captured information to the PC during capture. Recirculate Capture uses the Pod's RAM buffer as a circular buffer for maximum data rate capture. To change capture mode, click on the **CHG TYPE** button on the toolbar or type **ALT-R** (figure 5).

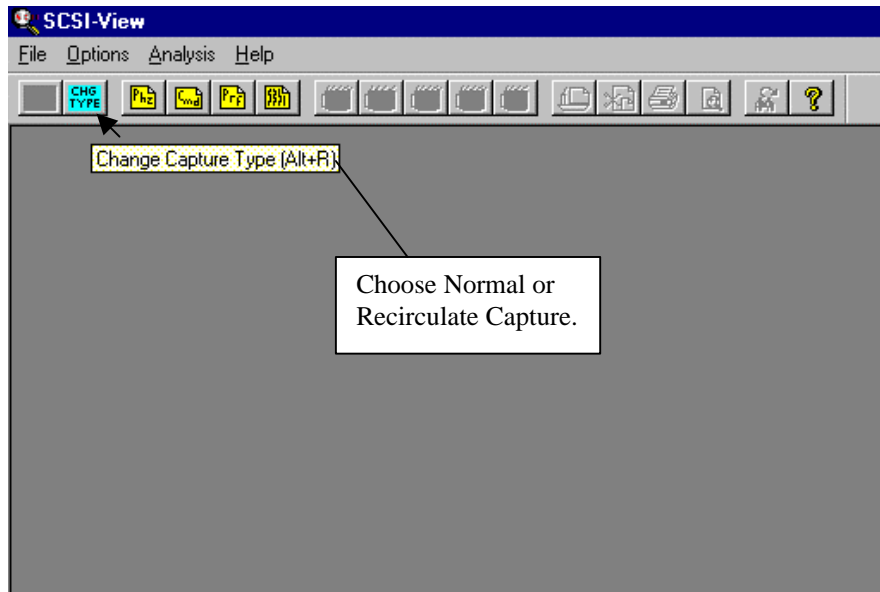

Figure 5

3.2.2 Performance Analysis

The Performance Analysis window (Figure 6) performs SCSI performance analysis from the current active SCSI capture session, or from previously captured session files. Performance analysis is useful for a wide range of applications, including finding performance bottlenecks, comparing the operation of peripherals from different manufacturers and for comparing different revisions of device firmware.

Performance analysis includes:

- Burst and Connect data rates (max., min., avg. and current).

- Time spent in each SCSI phase.
- Percentage of time devices are active on the bus, (% bus utilization)
- Number of Disconnects per command.
- Read / Write command completion
- Read /Write command to Read /Write command times.
- Total bus bandwidth and utilization percentage
- Tagged Queuing analysis (min, max, avg. depth).

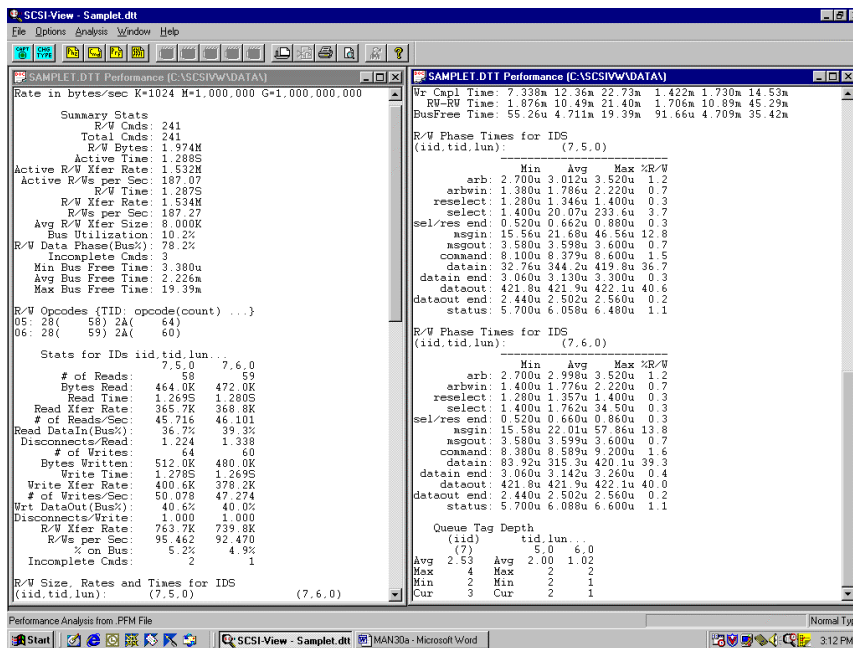

Figure 6

Performance analyses can be displayed in real time, on active SCSI systems, or on previously captured SCSI session files.

3.2.3 Protocol Analysis

Figure 7 shows SCSI-View configured with two protocol windows. These windows can use either the current real time SCSI capture session or a previously captured session as their source. Each window shows the same SCSI activity at a different level of detail.

- The **Command View** shows SCSI activity compressed into 1 entry per SCSI command operation, which spans the complete period from the initial arbitration to the bus free at the completion of the command, including disconnects. Each Command View item has a timestamp that represents one of four times: absolute time, difference time to the next command, completion time, or command time.
- The **Phase View** shows all low level SCSI phase activity, with time stamps for every phase. In this case, the displayed Phase View is linked to the Command View. Double clicking on any command in the Command View creates a new linked Phase View, with the cursor highlighting the first ARB of that command block. Cursor movement in the Command View is immediately reflected in the linked Phase View. In addition, several independent Phase and Command Views can be displayed at one time.

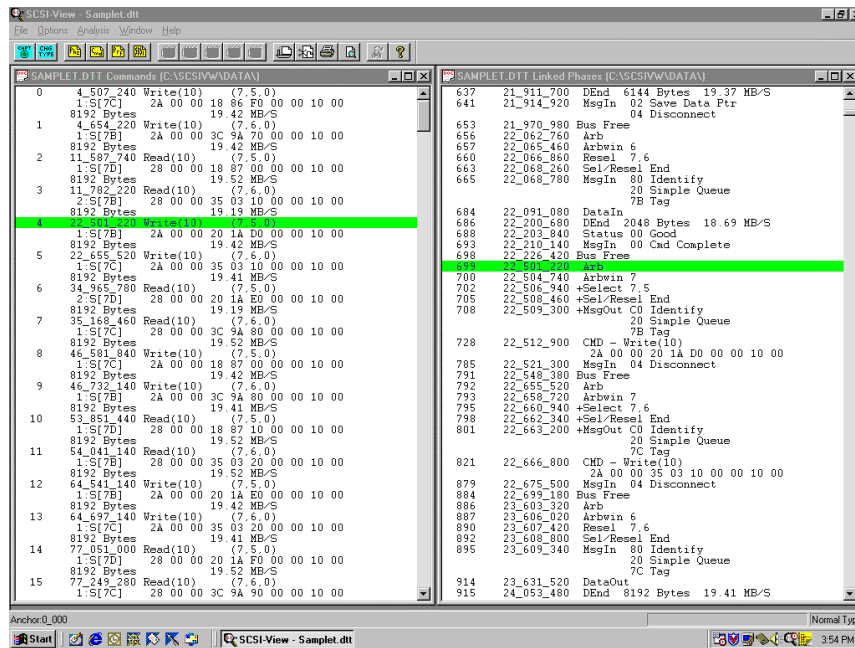

Figure 7

Event time is displayed with 4ns resolution (SV-8160), 5ns resolution (SV-3000), 10ns (SV-1620 / 1600), and can be shown either as absolute elapsed time or as difference time to the next event.

SCSI activity is updated in all windows as it occurs.

Windows can be re-arranged, scrolled, searched and filtered at any time, without stopping current SCSI protocol capture. (SCSI capture to disk can also occur even when no windows are actively displayed. Capture is independent of any display.) All windows can be filtered by Initiator ID, Target ID and LUN.

Protocol windows can also be opened on previous capture files for comparison with current SCSI activity.

Any display of the active capture session may be paused and searched without affecting the current capture to disk.

3.2.4 Timing View

The Timing View (Figure 8) displays each SCSI signal line in a number of formats. SCSI DATA PHASE Data can be displayed in Hex, Binary or Waveform formats. Waveforms can be displayed as Active High or Active Low with the active level denoted by a double line. See the **Popup Options (F2 or Right Mouse Button)**, for the Timing View to change these options.

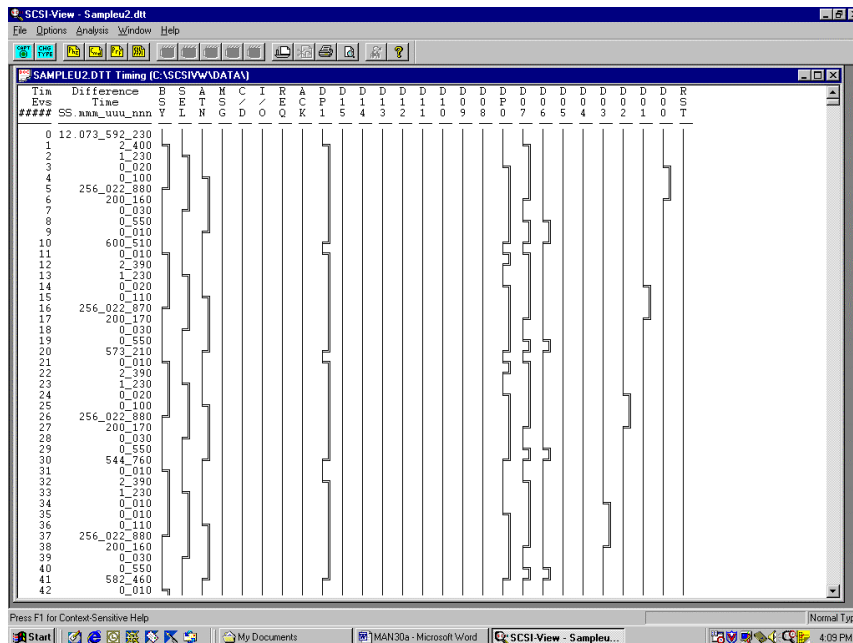

Figure 8

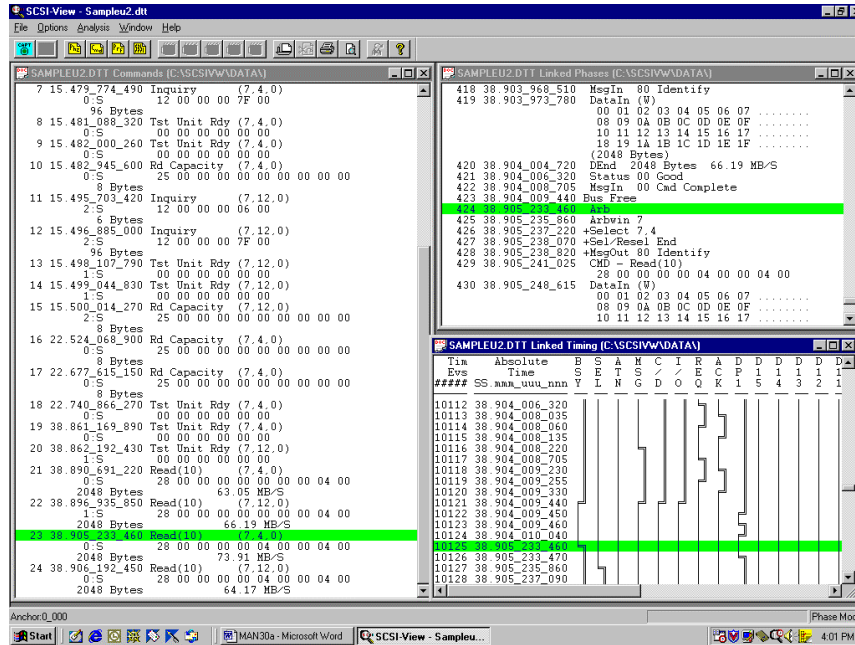

Figure 9

Linked Command, Phase and Timing Views

3.2.5 SCSI Search Capabilities

One of the largest hurdles to effective SCSI analysis is the analysis of large amounts of captured SCSI activity. SCSI-View can quickly search large SCSI capture files for a wide range of conditions. SCSI-View can search protocol files using any of the following methods:

- **Find Operation:** Searches on any Command, Message, Status or SCSI bus condition.
- **Find Phase Time:** Searches for the next phase, or group of phases that match the <, >, = time criteria.
- **Find Burst Rates:** Searches R/W data phases for burst data rates that match the <, >, = rate criteria.
- **Goto Event Number or Marker:** Jumps to the user specified phase / command number or a previously specified marker location.

- Find Operation, Phase Time and Burst Rate can also be filtered to only find matches within a specified ID and LUN group.

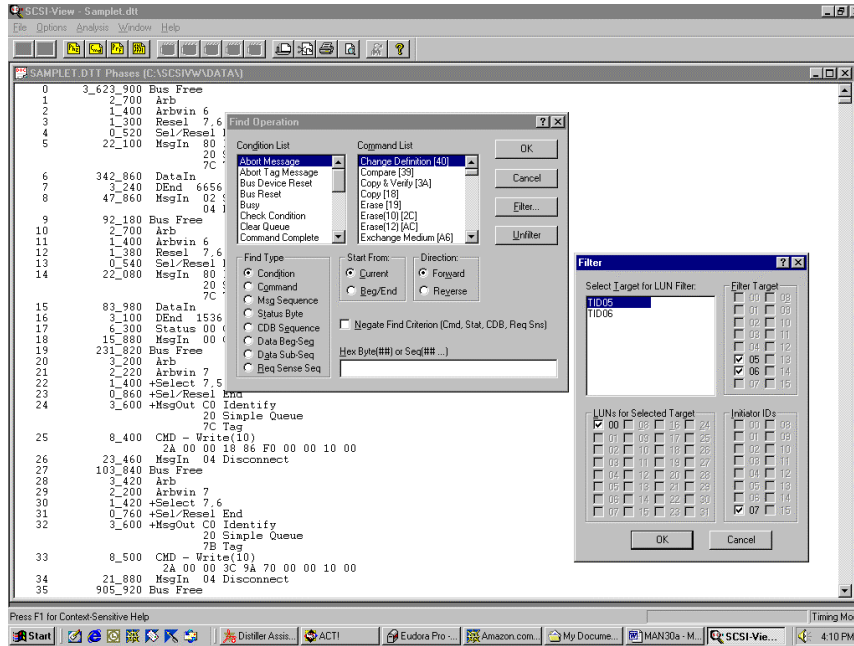

Figure 10

Search and Filter Options

3.2.6 Popup Menu Operations

The Phase and Command View Popup Menus (Figure 11 and Figure 12) show the range of Popup operations that are available by clicking the right mouse button, or pressing **F2**. These Popup menus provide quick access to screen format and display options, and to the **search** and **marker options** for each View.

✓ Line <u>N</u> umbers	
✓ Phase <u>E</u> vent Number	
✓ <u>E</u> vent Time	
✓ Difference <u>T</u> ime	
✓ <u>E</u> xtended Message	
✓ <u>D</u> isplay Data	
✓ Display <u>A</u> SCII	
Back <u>L</u> ink to Command	
<hr/>	
<u>G</u> oto Event Number...	Shift+F2
Find <u>O</u> peration...	Shift+F3
Find <u>P</u> hase Time...	Shift+F4
Find <u>B</u> urst Rate...	Shift+F5
Extract <u>S</u> ession File...	Shift+F8
Change Transfer <u>W</u> idths...	Ctrl+F2
Change Device <u>T</u> ypes...	Ctrl+F7
Set/Remove <u>A</u> nchor	Ins
<u>M</u> arkers...	Shift+F7
Open Data <u>W</u> indow	Alt+D
<u>L</u> ink to Timing View	Ctrl+F1

Phase View Popup Menu

Figure 11

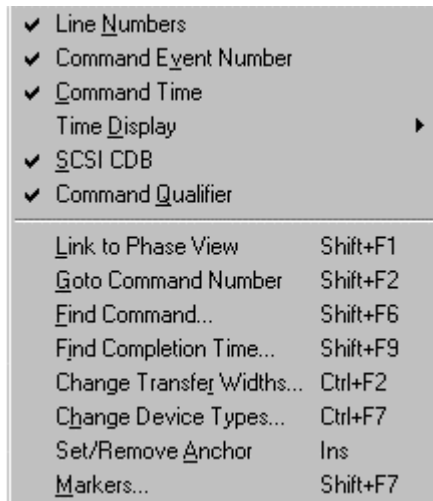

Command View Popup Menu
Figure 12

3.2.7 LED Indicators

The SV-8160 has two LEDs that display the analyzer's operational state. The LEDs are located on the side of the analyzer POD. The SCSI Status LED is at the SCSI connector end of the POD; the Analyzer Status LED is at the host connector end. For more detailed information, see Section 6.5 on page 114.

3.3 Summary

SCSI-View captures SCSI bus activity spanning long periods and provides multi-level viewing, powerful analysis and strong protocol searching of that activity. SCSI-View is an ideal tool for problem/failure analysis, device firmware qualification and comparison, performance analysis, protocol analysis, and detailed examination of phase level behavior of SCSI devices.

SCSI-View is useful in a wide range of applications, including peripheral device engineering, computer system engineering, software development, quality

assurance, system integration, peripheral sales support, field service and support, and all types of SCSI system testing.

- **SCSI-View provides detailed performance analysis of SCSI systems, (including Tagged Queue performance).**
- **Displays SCSI system problems and anomalies.**
- **Provides multiple levels SCSI protocol display and analysis detail.**
- **Runs in real time - SCSI activity can be captured, displayed and analyzed at the same time.**
- **Makes the detailed analysis of fast, complex SCSI systems over long time periods possible for the first time.**
- **Supports wide and narrow SCSI-1, SCSI-2, and SCSI-3 at up to Ultra3 (160Mb / sec. wide) speeds (SV-8160).**

Many SCSI problems that were very difficult, or impossible, to solve with other bus analysis instruments can be solved quickly and easily with SCSI-View.

4 SCSI-View Installation

4.1	INTRODUCTION.....	31
4.2	COMPUTER PLATFORM REQUIREMENTS.....	31
4.2.1	NOTEBOOK PCMCIA SETUP CONSIDERATIONS.....	31
4.2.2	Using the SCSI-View on ISA Bus Platforms (SV-ISA).....	32
4.2.2.1	Installing the SV-ISA on Windows 95 / 98 and Windows NT.....	32
4.3	SCSI-VIEW COMPONENTS and FILES	32
4.3.1	SCSI-View Software Installation (SV-8160 / SV-3000 / SV-1620) 33	
4.3.2	SCSI-VIEW Driver Installation.....	35
4.4	CHECK FOR PROPER HARDWARE INSTALLATION on WIN 95/98/2000	36
4.5	PROGRAM INSTALLATION INSTRUCTIONS.....	36
4.5.1	Reboot Windows and start SCSI-View.....	36
4.5.2	PCMCIA-02 Card Upgrade	37
4.5.3	SCSI-View Uninstall.....	37
4.6	Connecting SCSI-View to your SCSI system	38
4.6.1	SCSI Bus Termination	38
4.6.1.1	SV-8160, SV-3000, SV-1620 Hardware Options	38
4.6.1.2	Daisy-chaining to the end of the SCSI bus	39
4.6.1.3	Terminating ULTRA-1 SCSI Systems.	39
4.6.1.4	Connecting into the middle of the SCSI bus.....	39
4.6.1.5	Connecting to Differential SCSI Systems.....	39
4.7	Resolving SCSI-View Problems.....	41
4.7.1	No Hardware Detected	41
4.7.1.1	Symptom	41
4.7.1.2	Most likely explanations.....	42
4.7.2	SCSI-View Pod not detected; SCSI-View cannot start	43

4.7.2.1 Symptom.

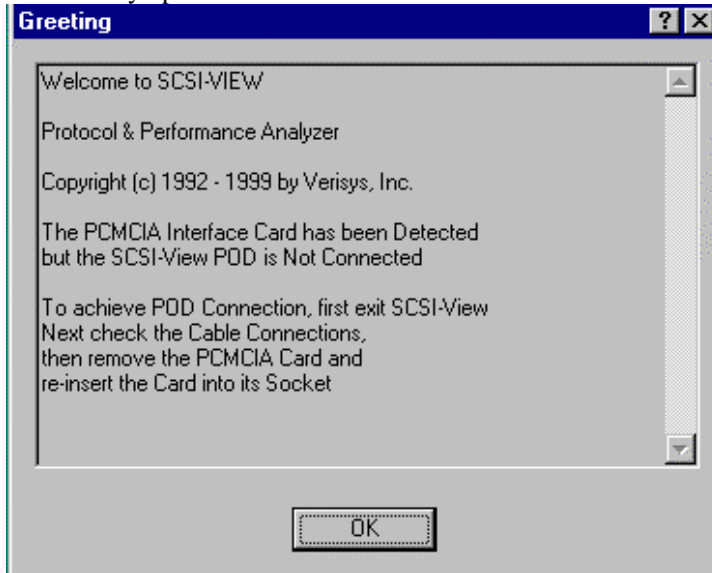

.....	43
4.7.2.2 Most likely explanations.....	43
4.7.3 No interrupts; SCSI-View Fails to Capture.....	44
4.7.3.1 Symptom.....	44
4.7.3.2 Most likely explanation.....	44
4.7.3.3 Troubleshooting IRQ conflicts.....	44
4.7.4 Memory and Buffer Allocation Issues.....	47
4.7.4.1 Symptom.....	47
4.7.4.2 Explanation.....	47

4.1 INTRODUCTION

This Chapter discusses how to set up and use Models SV-8160, SV-3000 and SV-1620 SCSI-View Analyzers. If you encounter problems after following these procedures, please contact Verisys for technical support.

SCSI-View software is designed to work with any Windows 95 / 98 / NT4.0 / 2000 system that supports Type-II or Type-III PC (PCMCIA) cards. SCSI-View will work with other PC cards in any slot. All SV-8160, SV-3000 and SV-1620 systems ship with SCSI-View for Windows 95 / 98 or Windows NT. (Please contact Verisys support if you need to run SCSI-View under DOS.)

Note: Running other Windows applications concurrently with SCSI-View will reduce its maximum SCSI capture rate.

4.2 COMPUTER PLATFORM REQUIREMENTS

4.2.1 NOTEBOOK PCMCIA SETUP CONSIDERATIONS

CPU requirements:

SCSI-View will typically be installed in a notebook PC through one of its Type II or Type III PCMCIA ports. The computer should contain a Pentium-class CPU. Users analyzing multiple ULTRA SCSI drives in a very active environment will most likely require a faster Pentium PC (133Mhz +). The speed of the Host PC determines the maximum target SCSI activity level that SCSI-View can capture and store to disk.

RAM/Hard drive requirements:

The host system should have at least 16MB of RAM (32MB for faster SCSI environments), 100MB of free hard disk space (for long SCSI capture sessions) and Windows 95 / 98 / NT4.0 / 2000. Simple, minimal capture SCSI sessions can be achieved with a smaller drive. Average SCSI capture sessions can create files of 1-10MB for several minutes of activity on a very active SCSI system.

Notebook power and power-save requirements:

During SCSI analysis and capture sessions, the PC should be externally powered rather than running off its internal battery pack. There are two reasons for this:

- Data capture sessions are often lengthy, and battery power failure during capture operation should be avoided.
- Most notebooks automatically disable their auto power down features when connected to an AC supply.

PC power-saving or auto power down features must be disabled.

If this is not done, capture sessions may be automatically aborted due to a perceived lack of keyboard or mouse activity. Refer to your computer's operations manual for instructions on disabling its power-save feature.

4.2.2 Using the SCSI-View on ISA Bus Platforms (SV-ISA)

The SV-8160, SV-3000 and SV-1620 PCMCIA products may be installed on a desktop ISA bus PC platform through use of the Verisys SV-ISA Adapter. Contact Verisys for ordering information on the SV-ISA.

4.2.2.1 Installing the SV-ISA on Windows 95 / 98 and Windows NT.

Refer to the "PC Card Reader Installation Guide" that accompanies the SV-ISA Adapter.

After installation, go to section 4.3.1 on page 33, to continue with the SCSI-View Windows 95 software installation.

4.3 SCSI-VIEW COMPONENTS and FILES

The standard components of the SV-8160, SV-3000 or SV-1620 are:

- PCMCIA interface card
- SCSI-View POD
- PCMCIA-to-Pod interface cable (C-0050)
- Universal AC Power Adapter (SV-8160 / SV-3000 only)
- SV-1620 and SV-1600 users may want to purchase the AK-1 or AK-2 adapter kits (see below).
- Installation CD-ROM for SCSI-View software and documentation

The SV-8160, SV-3000 and SV-1620 have a high-density 68-pin D-shell SCSI connector.

SCSI cable adapters available from Verisys:

A-0010:	High-density 50-pin D-shell SCSI to 50-pin male IDC ribbon cable connector for the SV-8020 only.
A-0020:	High-density 68-pin D-shell SCSI to high-density 50-pin D-shell SCSI. (SV-8160, SV-3000, SV-1620)
A-0030:	High-density 68-pin D-shell SCSI to 50-pin male IDC ribbon cable connector (SV-8160, SV-3000, SV-1620)
A-0040	High Density 68-pin SCSI Y Adapter. Puts SCSI-View in the middle of SCSI busses. One male and two female 68 pin connectors. (SV-8160, SV-3000, SV-1620)
AD-SCA	SCA to LVD/SE Adapter. Adapts 80 pin SCA connector to 68 pin standard SCSI.
AK-1:	Combination of the A-0020 and A-0030 Wide-Narrow adapters (SV-8160, SV-3000, SV-1620)

AK-2:	A-0020 / 0030 Wide Narrow adapters, A-0040 'Y' adapter and SCSI-1, SCSI-2 and SCSI-3 cables. (SV-8160, SV-3000, SV-1620)
-------	--

(SV-8160, SV-3000, SV-1620 / Windows 95/98 Windows NT)

Installation CD-ROM has the following directories:

Root	Autorun, SETUP.*,	Software Installation Routines
SVWIN2K	svdrvr2k.inf	32 bit analyzer driver
	svdrvr.sys	
	svpci.sys	
SVWIN9X		
	svdrvr9x.inf	
	svdrvr.vxd	
SVNT40	svpci.vxd	
SVREADER	SETUP.*, _SETUP.*, ...	SVREADER Runtime Software
MANUAL	MAN30.PDF, MAN.HTM + *.GIF, MAN.DOC	SCSI-View Manual in three formats
ACROBAT	AR32E301.exe	Acrobat Reader 3.01
Disks.w2k	DISK1.EXE, DISK2.EXE	Self extracting diskette images for SCSI-View installation
Disks.w9x		
Disks.nt4		

Please verify that you have received all of these components before attempting to use the product. (SCSI-View for the SV-8160, SV-3000 and SV-1620 ships only with Windows software. Please contact Verisys support if you need a DOS version.)

4.3.1 SCSI-View Software Installation (SV-8160 / SV-3000 / SV-1620)

Installation of the SCSI-View system on Windows 95 / 98 and Windows NT equipped computers is straightforward. **The software installation consists of three steps:**

1. Insert the SCSI-View PCMCIA card or PCI Host Adapter and install the driver.
2. Run setup from the installation CD-ROM to install the main SCSI-View

software.

3. Re-Boot Windows and start SCSI-View.

4.3.2 SCSI-VIEW Driver Installation

On new installations, when either the Verisys PC Card has been inserted into one of the PCMCIA slots or the Verisys PCI Host Adapter is detected, Windows 95 / 98 / 2000 will display a New Hardware Found dialog. *Note: Driver installation for Windows NT4.0 is achieved via installation of SCSI-View software.*

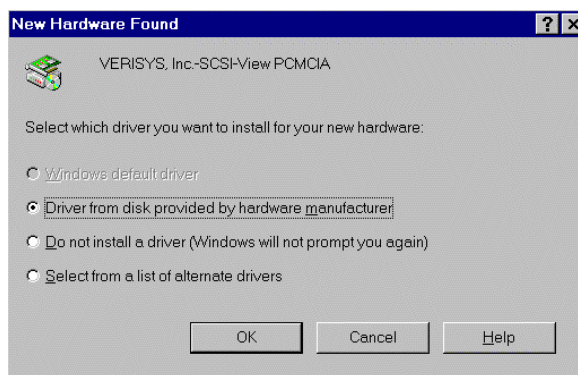

• Figure 13

- For Win 95 select the option “Driver from disk provided by hardware manufacturer”.
- For Win 98 / 2000 select the wizard option to “Search for a suitable driver for my device (recommended)”. Put a check mark in the box next to “Specify a location”.
- Insert the SCSI-View CD-ROM into its drive – setup should launch automatically. Wait for the Installation Menu screen to appear.
- Cancel out of the CD-ROM Installation Menu.
- When the wizard prompts for an installation directory enter:
For Win 95/98: D:\svwin9x where D: represents the CD-ROM drive letter.
For Win 2000: D:\svwin2k where D: represents the CD-ROM drive letter.
Then press the OK button.

4.4 CHECK FOR PROPER HARDWARE INSTALLATION on WIN 95/98/2000

- Select **Start, Settings, Control Panel**.

For Windows 95/98:

- In the Control Panel, run **System** and select the Device Manager Tab. The device Bus Analyzer preceded by a gray diamond should be present in the list of devices viewed by type.
- Either “Verisys, Inc.-SCSI-View_PCMCIA_Card” or “Verisys, Inc.-PCI_Board” preceded by a gray diamond should be below Bus Analyzer. If an exclamation point, red ‘X’, or question mark appears on the diamond, select **Properties** on the selected device to troubleshoot the problem.

For Windows 2000:

- In the Control Panel, run **System** and select the Hardware Tab, **Device Manager**. The device PC Card / PCI Bus Analyzer preceded by an adapter card icon, should be present in the device list.
- Either “VERISYS_Inc.- SCSI-View_PCMCIA” or “Verisys, Inc.-PCI_Board” preceded by an adapter card icon, should be below PC Card / PCI Bus Analyzer. If an exclamation point, red ‘X’, or question mark appears on the icon, pick **Action, Properties** on the selected drive to troubleshoot the problem.

4.5 PROGRAM INSTALLATION INSTRUCTIONS

- For Windows 95 / 98 / NT4.0 / 2000
- Insert CD-ROM. Setup should launch automatically. If not, open the Add/Remove Programs applet from the Control Panel and click on the Install push button.
- When the Install SCSI-View button is pressed, the installation program will detect which Windows operating system is running and will load the appropriate installation software.
- See the readme.txt in the SCSI-View Installation or in the destination directory for the latest Release Notes.

4.5.1 Reboot Windows and start SCSI-View

After installation completes, you will be asked if you want to reboot the computer. Answer YES. (If you answer no, you must reboot prior to running

SCSI-View the first time by selecting Start, Shutdown, Restart the Computer.)

Double clicking on the new SCSI-View icon on the Windows desktop will now start SCSI-View.

4.5.2 PCMCIA-02 Card Upgrade

Brand new SV-8160 / SV-3000 / SV-1620 installations: Do not perform this step.

This step is ONLY for PCMCIA-02 cards shipped prior to Oct. 6, 1997.

All revisions of SCSI-View 2.13 and later depend on Windows Plug & Play for allocation of PC-Card I/O addresses and interrupt resources. As such, the PC-Card used to interface the SCSI-View analyzer must be Plug & Play compliant.

If you have a PCMCIA-01 card, or an older PCMCIA-02 card that is not Windows Plug & Play, please contact Verisys to arrange for your card to be returned and upgraded.

4.5.3 SCSI-View Uninstall

Removal of the SCSI-View software should be done through the Windows control panel rather than by deleting files.

1. Select Start, Settings, Control Panel, Add/Remove Programs.
2. Highlight SCSI-View in the software list.
3. Click on the Add/Remove Programs button.
4. Follow the prompts to remove SCSI-View.

4.6 Connecting SCSI-View to your SCSI system

4.6.1 SCSI Bus Termination

The SCSI-View Pod may be connected to the SCSI bus at either end or anywhere between the ends. Verisys recommends connection at the end of the bus if feasible.

SCSI-View enables and disables its active SCSI terminator from the **OPTIONS, HARDWARE** dialog.

4.6.1.1 SV-8160, SV-3000, SV-1620 Hardware Options

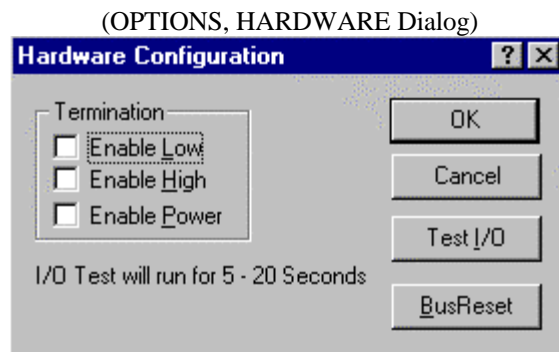

Figure 14

Options, Hardware screens

Termination can be individually enabled for both the low data bus plus control lines, and for the high data bus.

Note: When the analyzer is connected to a narrow 8 bit SCSI bus through a cable converter, the **Enable High** should be selected. This should be done even when termination is not being provided by the analyzer to the low data bus. This forces the upper data bus to an inactive level for the analyzer, which prevents erroneous capture of upper ID bits during ARBITRATION and SELECTION / RESELECTION from the unconnected (floating) upper SCSI data bus. (Also, check **Enable Low** if the analyzer is providing termination to the narrow SCSI bus).

4.6.1.2 Daisy-chaining to the end of the SCSI bus.

Typically, this connection is made by connecting a cable from the SCSI connector on the Pod (using a cable adapter as needed) to the daisy-chain connector on the end device in the SCSI system under test. When SCSI-View is placed at either end of the bus, it must usually provide SCSI termination, which is accomplished by checking the Termination **Enable Low & Enable High** checkboxes.

Check the termination status of the SCSI device, which *normally* resides at the far end of the daisy chain. If this device is terminated (and it should be), you should remove termination from the device while the terminated SCSI-View Pod is occupying the end-of-chain position on the bus. If this is not possible, then use a very short cable between the SCSI-View Pod and the last device and do not enable termination from the SCSI-View Pod.

4.6.1.3 Terminating ULTRA-1 SCSI Systems.

The cabling and termination of ULTRA-1 SCSI systems is much more critical than other SCSI systems. In general, Ultra-1, Fast-20 systems require shorter cables (1.5 meters) and termination at both ends of the cable. The best results will occur when the SCSI-View Pod is placed at one of the cable ends with the Initiator at the other end. In this case, the SCSI-View Pod and Initiator supply termination.

4.6.1.4 Connecting into the middle of the SCSI bus.

SCSI-View can also be connected between devices in the middle of the SCSI bus. This is typically done by making a connection between an existing female connector in the middle of the 50/68 pin SCSI ribbon cable and the 50/68 pin male connector provided by one of the SCSI-View cable adapters attached to the Pod's SCSI connector. In this configuration, SCSI-View's Termination enabled check box should not be marked.

4.6.1.5 Connecting to Differential SCSI Systems.

The SV-8160, SV-3000 and SV-1620 have differential interface receivers for usage with differential SCSI systems (LVD and HVD on the SV-8160, LVD only for the SV-3000, HVD only on the SV-1620.) To enable this interface mode, check the Differential Enable checkbox. The termination hardware will automatically use the switchable differential terminators when Differential Mode is enabled.

<p>Note: The SCSI-View differential interface uses the TERM POWER being supplied by the host adapter for its operation. If TERM POWER is not available, it is possible to supply power to the differential terminators and receivers by checking the ENABLE POWER checkbox located below the TERMINATION</p>

check boxes. SCSI-View may capture invalid SCSI information if TERM POWER is not present and ENABLE POWER is not checked.

Supplying termination and differential interface power from a notebook may exceed the power supply capabilities of some notebook PCMCIA card interface circuitry (the notebook may just switch off power to a card that draws too much current). Check the owner's manual of the notebook being used to determine if there are current supply limitations. The maximum power that may be supplied by the PCMCIA card interface when ENABLE POWER is checked could be 0.45 amps.

The SV-8160 and SV-3000 also include an external power supply for conditions where the notebook PC cannot provide enough power for operation. This can also be used to power the PODs for stand-alone SCSI capture while disconnected from the PC.

4.7 Resolving SCSI-View Problems

There are three distinct kinds of problems that generally arise in SCSI-View installations:

- The SCSI-View software does not detect the presence of a PCMCIA port in the computer.
- The SCSI-View software sees the PCMCIA port, but cannot detect its own hardware, the SCSI-View POD.
- The PCMCIA and SCSI-View hardware are detected and SCSI-View appears to run, but when the data flow rate requires the use of hardware interrupts, an error message appears stating that interrupts aren't working, and the capture session terminates.

Fortunately, resolving these problems is usually straightforward. This section will discuss each of the three scenarios summarized above, and present appropriate courses of action.

4.7.1 No Hardware Detected

The basic problem here is that the PCMCIA driver software (the link between the SCSI-View software and the PCMCIA hardware) is missing or non-functional, and consequently the PCMCIA port is not responding to calls from SCSI-View. (Other PCMCIA devices and applications will also appear non-operational.)

4.7.1.1 Symptom.

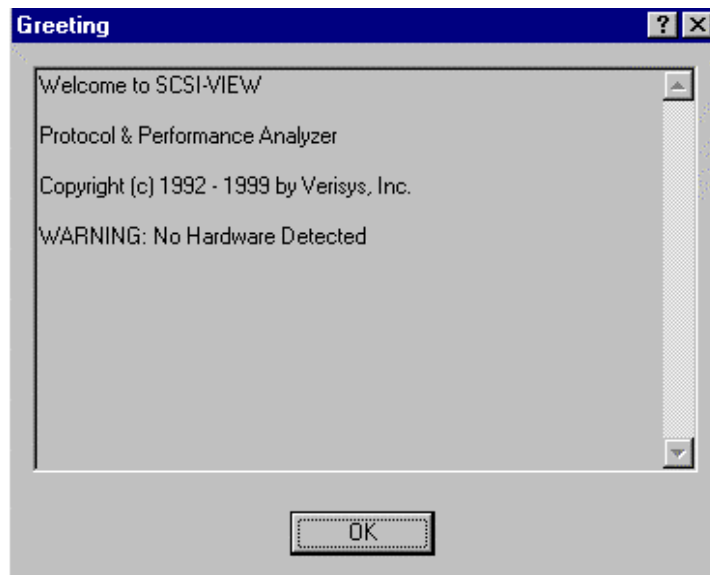

Figure 15

4.7.1.2 Most likely explanations.

- The drivers you installed are not PCMCIA 2.00-compliant (i.e., they are down-revision).
- The PCMCIA driver's system memory space is being overwritten by another device driver, which has been loaded into upper memory. (DOS only)

The remedies for most of these problems are either self-explanatory, or are discussed in detail earlier in this chapter. The next section discusses some troubleshooting ideas for resistant memory allocation problems.

4.7.2 SCSI-View Pod not detected; SCSI-View cannot start

The basic problem here is that communication between the PCMCIA port and the SCSI-View Pod is not occurring. Since this is a problem specific to the SCSI-View installation, other PCMCIA devices will most likely work normally.

4.7.2.1 Symptom.

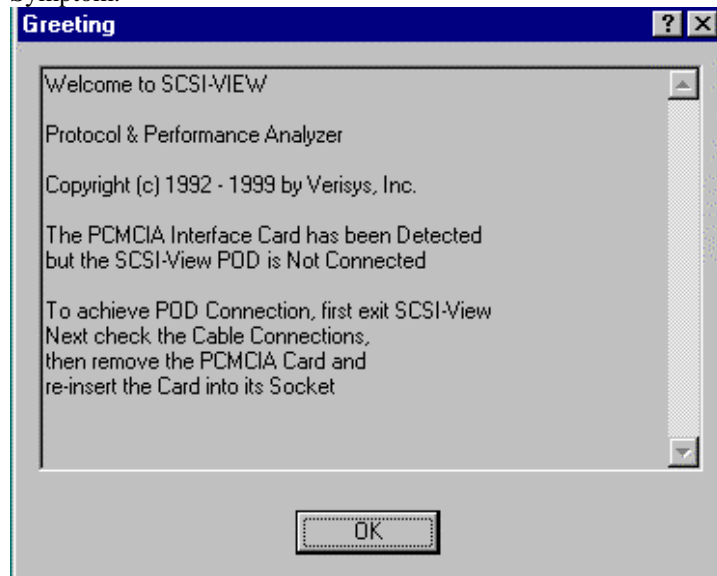

Figure 16

4.7.2.2 Most likely explanations.

The following problems can cause SCSI-View I/O communication failure:

- The PCMCIA card is not fully seated in its socket.
- The supplied cable, which connects the SCSI-View Pod (computer side) to the PCMCIA card, is bad, or is not connected properly. (Make sure the cable is screwed into the POD connector.)
- The SCSI-View Pod is trying to utilize an I/O address, which is being used by another device.

The remedies for the inter-connectivity problems are for the most part self-explanatory. See *Connecting SCSI-View to your SCSI system*, on page 38, for details on connectivity and termination. The next section discusses some troubleshooting ideas for solving I/O addressing problems.

4.7.3 No interrupts; SCSI-View Fails to Capture

When SCSI-View's data capture FIFOs are half full, SCSI-View will force a hardware interrupt so the computer can pause its current task and handle the captured data immediately. If the computer does not acknowledge this interrupt, SCSI-View will halt the capture process and report an error. In addition, certain IRQ conflicts can actually cause more severe problems, such as not allowing SCSI-View to run at all.

4.7.3.1 Symptom.

'No Interrupts' dialog box displayed during capture or SCSI-view fails to capture anything while in Timing mode capture. (Phase mode capture may still work.)

4.7.3.2 Most likely explanation.

The IRQ address selected by the SCSI-View PCMCIA driver is already being used by another device. SCSI-View requires one interrupt to operate properly.

4.7.3.3 Troubleshooting IRQ conflicts.

How SCSI-View picks an IRQ.

Unlike most conventional bus hardware devices, plug and play PCMCIA devices utilize the Card Services driver, which locates and assigns IRQs the same way it assigns I/O memory space—that is, based on its knowledge about IRQs already in use by other devices. SCSI-View will request a specific interrupt from the PCMCIA card services driver. If the driver rejects that interrupt, SCSI-View requests the next one in its list. As with I/O space selection, the success or failure of this method is tied to how well existing devices make their IRQ utilization visible to the PC's operating system. Though this system usually works, instances do occur where the PCMCIA Card Services driver will assign SCSI-View an interrupt that is already in use.

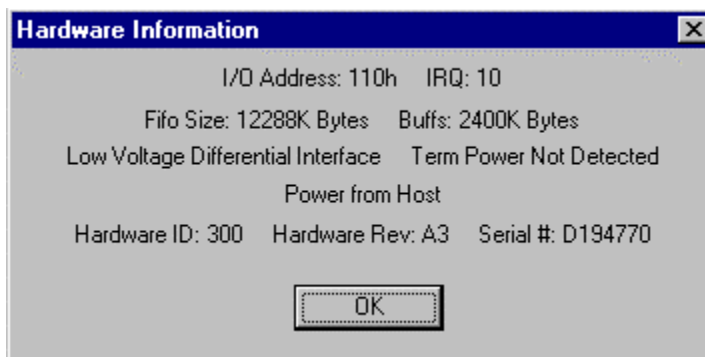

Hardware Information Screen
Figure 17

To see which IRQ has actually been granted to SCSI-View, access the **File, Hardware Information** menu (Figure 17) from the SCSI-View menu bar.

Modifying the IRQs requested by SCSI-View (Windows 95/98).

SCSI-View can use interrupts 10,11,12,15,7,3,4,5,6. Interrupts 10 or 11 are usually the most likely to be free. The interrupt used by the SCSI-View VXD driver can be changed via the Windows control panel. To change the interrupt, do the following:

- Select **Start, Settings, Control Panel**.
- Select the **System Icon** by double clicking on it.
- Choose the **Device Manager** tab at the top of the window.
- Double click on **Bus Analyzer**.
- Double Click on **Verisys, Inc.-SCSI-View_PCMCIA_Card**.(Figure 18)
- Chose the **Resources** tab at the top of the screen.(Figure 19)
- Uncheck **Use Automatic Settings**.

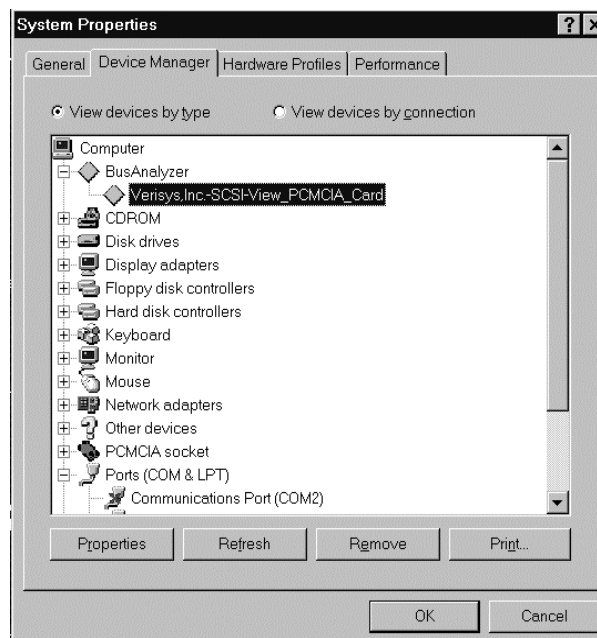

Figure 18

- Double Click on the **Interrupt Request** entry to change the selected interrupt.
- Select a new interrupt. The interrupt conflict status is shown in the box below the interrupt. (**Error! Reference source not found.**)

- Click on OK to exit each dialog.

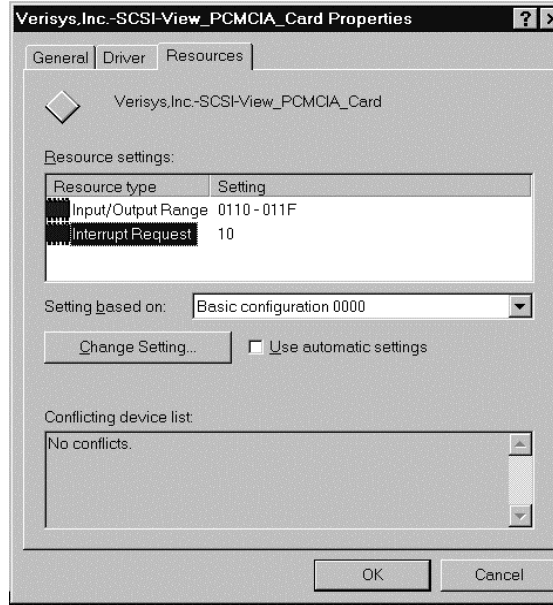

Figure 19



Figure 20

- Choose **Start, Shutdown, Restart the Computer** (The new interrupt will NOT be used until a re-boot has occurred.)

- Start SCSI-View and check that new interrupt is in use by selecting the **File, Hardware Information** dialog.

4.7.4 Memory and Buffer Allocation Issues

4.7.4.1 Symptom

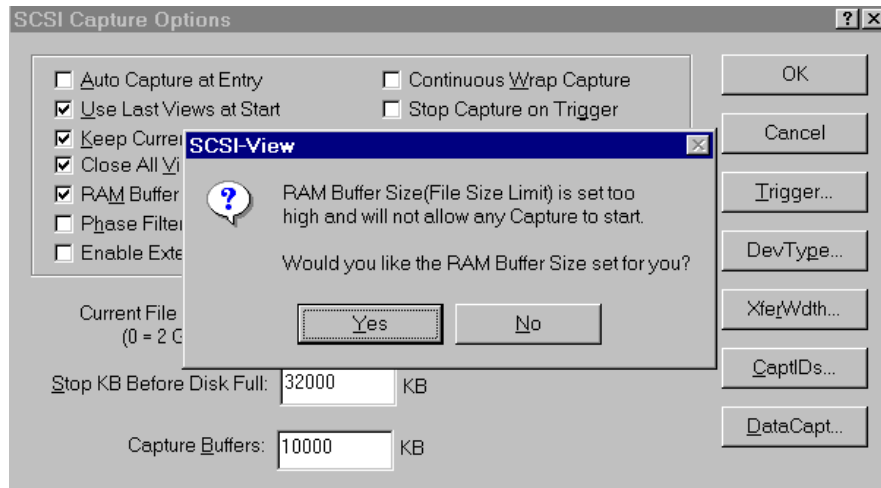

Figure 21

4.7.4.2 Explanation

Either too large a Current File Size Limit has been set in RAM Buffer mode or too much Capture Buffer RAM has been requested in the **Options, Capture Options** dialog (Figure 22).

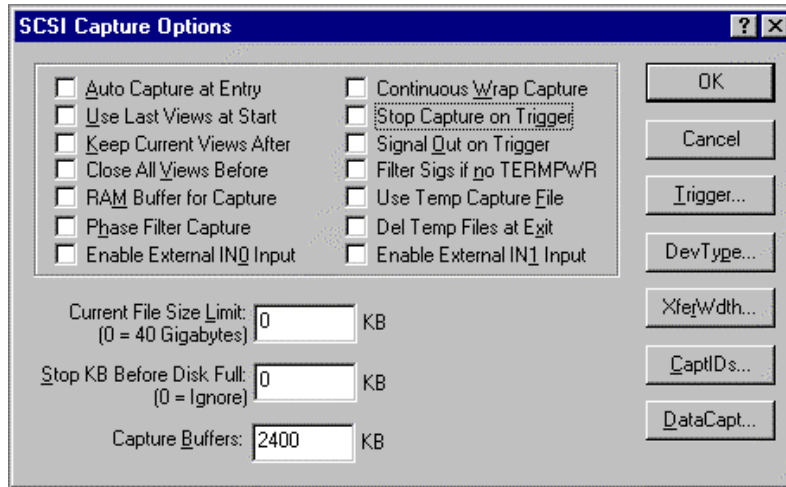

Figure 22

SCSI-View for Windows requires 'locked' system memory for its RAM Buffer and Capture Buffer. The availability of locked buffers is somewhat fluid under Windows operating systems. This depends upon the number of applications running (including minimized programs), and the types of system activity generated by each application. The same amount of locked RAM allocated to SCSI-View at start up may not be available if other applications are running or have previously run. Running a large number of simultaneous applications can also reduce the overall performance of SCSI-View.

Answer **YES** (Figure 21), and let SCSI-View set the buffer value for you. If this value is much smaller than desired, shut down other unneeded applications. Re-Booting Windows can also free up additional memory.

Note: SCSI-View for Windows should be run on at least a 16MB system, with 32MB or more optimal for buffering. A maximum of 32000 x 1024 bytes (32MB) of RAM buffer and 12000 x 1024 bytes (12MB) for Capture Buffering can be set in the Capture Options dialog. These two values impact one another. The default setting for Capture Buffers is 2400 (2.4MB). The RAM Buffer (used as a RAM-DISK) can be set to any desired value up to 32000 (32 MB).

5 Quick Start - Analyze SCSI Activity

In This Chapter:

5.1	SCSI-View Quick Start Summary	51
5.2	Starting SCSI-View	53
5.3	Starting and Stopping SCSI Capture (Alt-C).....	54
5.4	The SCSI Command and Phase Views	57
5.5	Moving Around Analysis Views	59
5.6	Searching Protocol Capture Files	61
5.7	Filtering Views for Specific Device ID's and LUN's	64
5.8	The Performance View	65
5.9	On line HELP (F1).....	66
5.10	Exiting SCSI-View (ALT-X)	66

5.1 SCSI-View Quick Start Summary

To Start / Stop SCSI Capture:	Type ALT-C at the SCSI-View Main Screen (CTRL-C will also end any capture.)
To Toggle between Normal and Re-circulate Capture Type (SV-8160 / SV-3000):	Type ALT-R , The capture mode will toggle between Normal and Re-circulate types..
To Toggle between Phase and Timing Mode Capture (SV-1620 / SV-1600):	Type ALT-M , or click on BegPhsCapt / BegTimCapt on the status line. The capture mode will toggle between Phase and Timing waveform modes.
To Open Current (real time) Phase, Command and Performance Windows:	Use Analysis, Curr Phase, Command, Performance and Bus Inspector after starting a capture. (Normal Type capture only.)
To Open Previous Capture Files for Viewing:	Use Analysis, File Phase, Command and Performance.
To Set up Triggers:	Check the Trigger box in Options, Capture Options (F4) , and enter Trigger setup by pressing the Trigger Button in this dialog.
To Set up SCSI Termination and Single Ended or Differential mode capture:	Use Options, Hardware (ALT-T) and check the appropriate boxes. (Remember to check the Enable High box if you are capturing with a wide-narrow cable adapter. This will prevent SCSI-View from seeing floating high order select IDs).
To Print a Phase, Command, Timing or Performance View:	Highlight the desired Phase, Command or Performance View by clicking on it with the mouse. (After opening it with the Analysis menu). Chose File, Print..
To link to Phase View from Command View or to link to Timing View from Phase View.	Double click on a command in Command View to link to Phase View. Double click on a phase in Phase View to link to Timing View.
To Search a capture file for SCSI	After opening the desired Analysis View for Phases or Commands, Right Click the

<p>Conditions, Command CDBs, Message Bytes, Data Sequences, Phase Times, Burst Rates and Command Completion Times:</p>	<p>Mouse (or Press F2) while highlighting the desired Analysis View. This will display the Search and Formatting Popup Window.</p> <p>Use Find Operation, Find Phase Time and Find Burst Rates for the Phase View. Use Find Command or Find Completion Time for Command View.</p>
<p>To get detailed On Line Help (Context Sensitive):</p>	<p>Press F1 at any point in the program. Help will display information on the active menu item, dialog or Analysis View. Pressing F1 while viewing the Phase, Command and Performance Views gives detailed information on their Protocol Display formats. In Performance, Help also describes the formulas used to calculate each performance value. Use Help, Index to search for a specific Help item.</p>

5.2 Starting SCSI-View

(NOTE: This section uses the example SCSI capture file, sample.dat, to illustrate each of SCSI-View's features. If you have already plugged the SCSI-View cable into your SCSI system bus, and SCSI activity is taking place, you can analyze your current SCSI activity instead of the sample file by using the CURRENT options instead of the FILE options presented when each analysis window is opened). To freeze display updates, left click on any display line. The current file can then be scrolled and searched like any other capture file. Left click again on the highlighted line, or press ESC to resume active display update.

To start SCSI-View click on the SCSI-View ICON. The initial SCSI-View display shows an empty desktop (Figure 23). Analysis windows can be opened to start Performance, Problem and Protocol analysis on current SCSI activity, or previously captured SCSI activity.

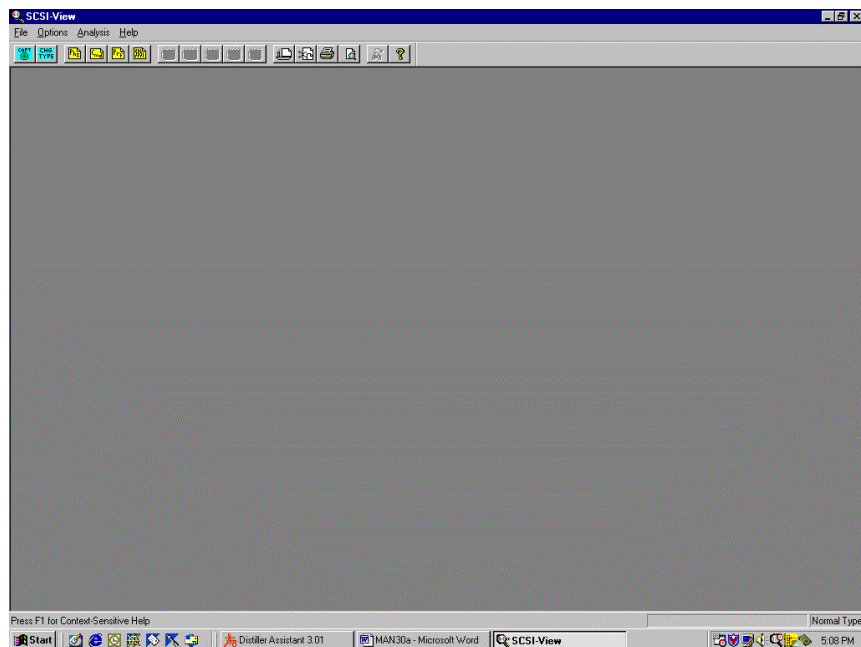

Figure 23

Note: SCSI-View has extensive context sensitive help. Help includes complete descriptions of every Phase, Command and Performance display item and 'how to use' instructions for each feature. Press F1 for a complete help description of the current displayed analysis View or menu item. For a more structured on line description see the **Help, Index** menu item for a complete hypertext linked description of how to use SCSI-View.

5.3 Starting and Stopping SCSI Capture (Alt-C)

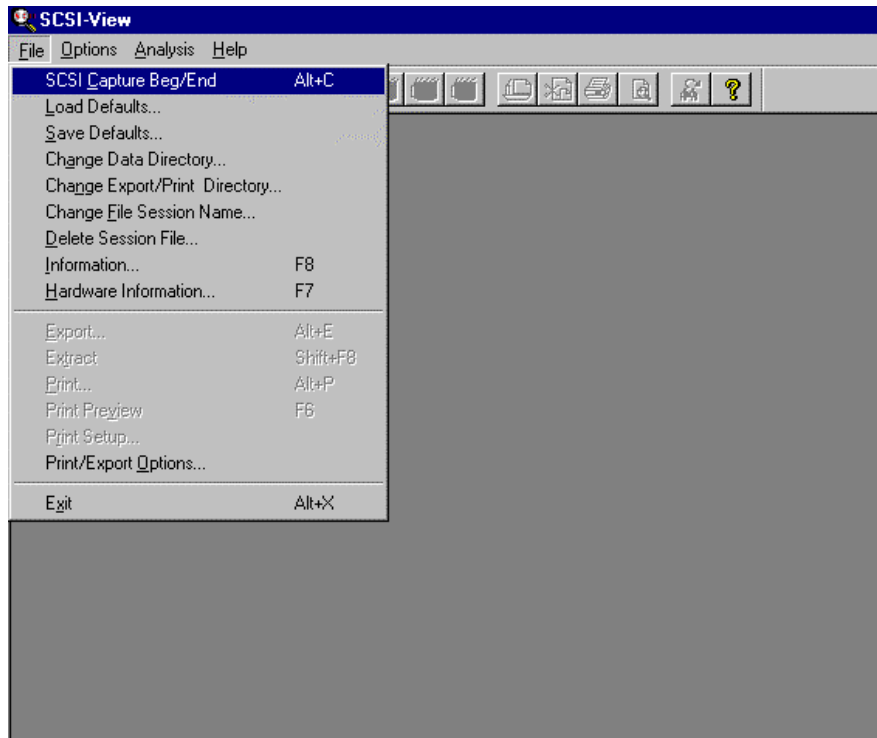

Figure 24

When it is first started, SCSI-View defaults to the capture OFF mode. To start capture of SCSI activity, click on **FILE, SCSI Capture Beg/End** from the main menu. SCSI capture will start, and the status line at the bottom of the display will show the current capture file size in Kbytes, and the Capture ON/OFF status. To stop SCSI capture, click again on **FILE, SCSI Capture Beg/End**. (Alternatively, click on **Beg/End Capture** on the status line, or type **<ALT> c.**) SCSI capture will then be halted, and the current capture file will be closed. Capture can also be started or stopped by clicking on the Capture button on the toolbar.

It is not necessary for an analysis window to be active in order to capture SCSI activity. SCSI-View automatically opens a new file, (sequentially named SV0.dat, SV1.dat, etc.), when capture is started. Capture to this file takes place regardless of whether an analysis window for that file is being displayed. Both this 'current' file and any previous capture file can be viewed and analyzed while capture is on.

After selecting **SCSI Capture Beg/End**, a session dialog will appear (see

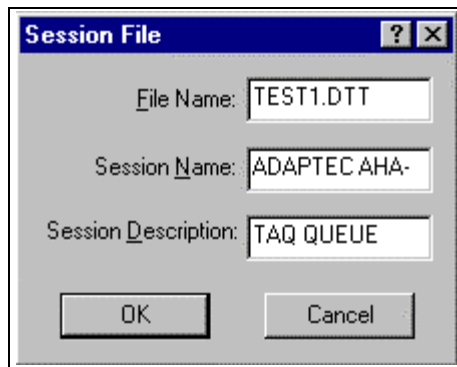

Figure 25). This dialog will allow the file name, session name and session description to be edited before actually starting the capture.

After editing the names and description, clicking on the OK button or pressing ENTER will start the capture session. The indication that capture has been started and the current session file size is the status line display [file=xxxx] (see Figure 26).

Figure 25

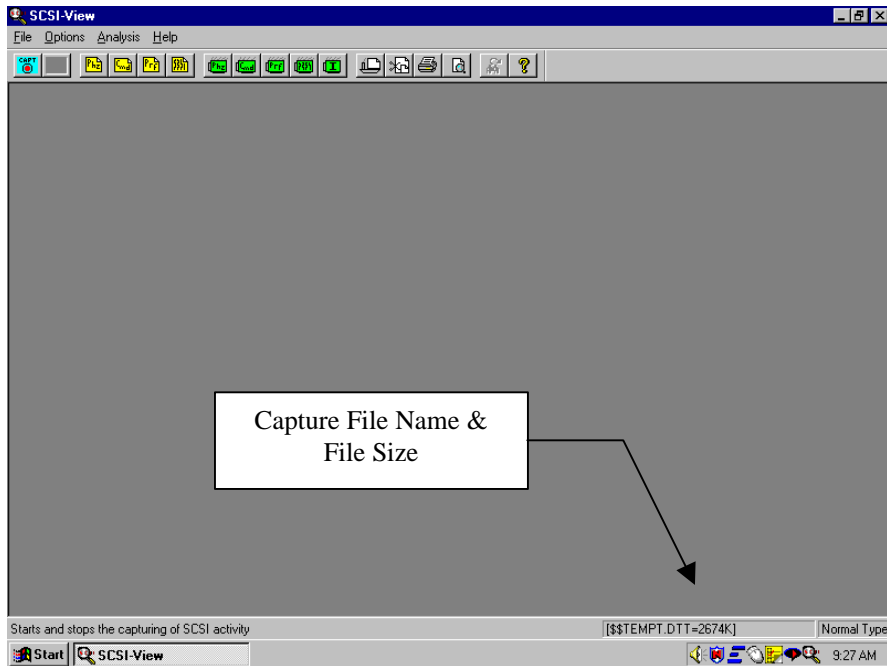

Figure 26

The Session Name and Session Description can be changed at any time during or after beginning a SCSI capture. Remember that the Session Name is a name managed by SCSI-View and is separate from the filename.

Capture and analysis functions operate independently from one another. Views can be open for any combination of current and previous capture files. When an analysis View is open for the current capture file, all new SCSI activity will be reflected in that window as it occurs.

5.4 The SCSI Command and Phase Views

The Protocol Analysis window is used to display current or previously captured protocol activity files. Multiple protocol View windows can be open at one time. Multiple protocol View windows can be used to compare current and previously captured SCSI activity, to display current SCSI activity filtered for different SCSI ID and LUN values and to display SCSI activity at different levels of detail.

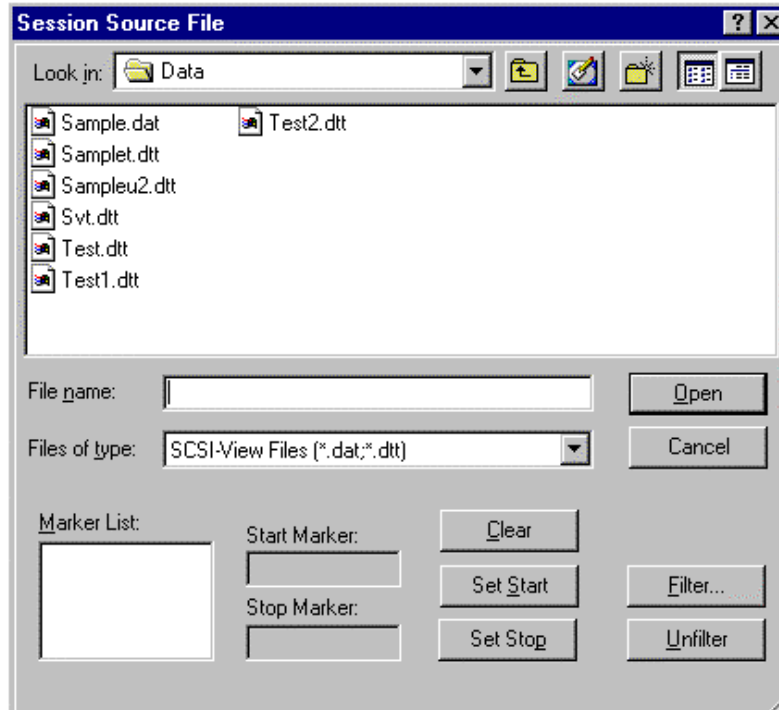

Figure 27

To open a Command View on a captured session, select **Analysis, File Commands**. The file selection dialog, (Figure 27), will then display.

The Files box displays a list of available capture files. In this case, click on SAMPLE.DAT, and then click on OK. A command level protocol window for Sample.dat will then be displayed, (Figure 28).

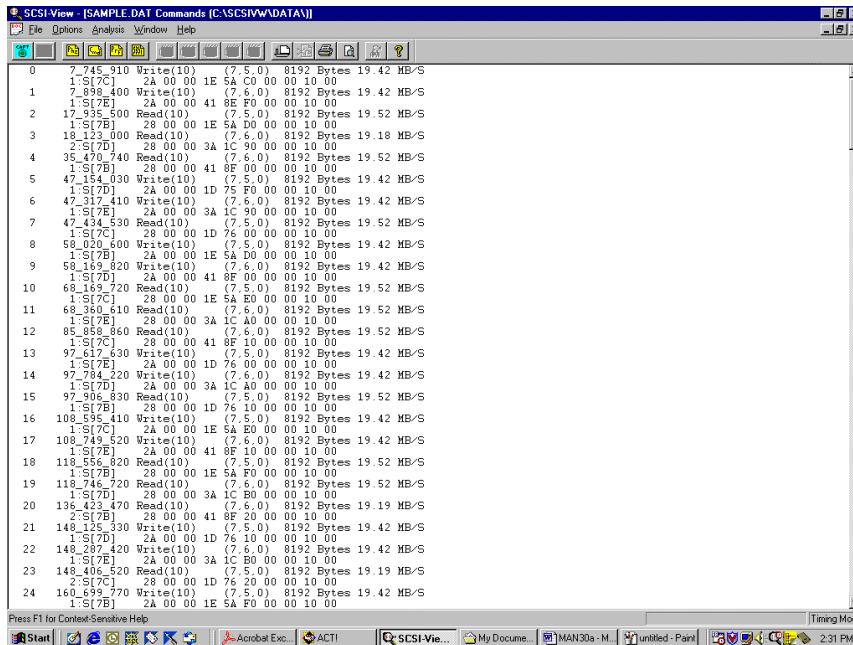

Figure 28

A number of analysis windows can be opened on the screen at one time, (subject to available screen space). All 'current' windows on the screen reflect current SCSI activity. For instance, windows can be opened to view the current Protocol Capture file, previous Protocol Capture files, current SCSI Performance information and current SCSI Problem information. Analysis windows can also be opened on the same file, but with different filtering criteria. One window may be set to filter for Device 0, and another set to display all device activity.

To open a linked Phase View from the current Command View, double left click on any line in the Command View. A new Phase View of the same file will appear centered on the highlighted command.

Any movement to a new command line in the Command View will cause a corresponding movement to the initial ARB phase for that command in the linked Phase View. Linking is a useful method for scanning a Command View while maintaining a detailed display for each command.

Pressing the + key will move the linked Phase View to the next reselect portion of the current command, if that command has disconnected and reconnected from the bus. In this manner, the complete thread of a single command can be walked forwards and backward by pressing the + and - keys while in a linked Command - Phase View.

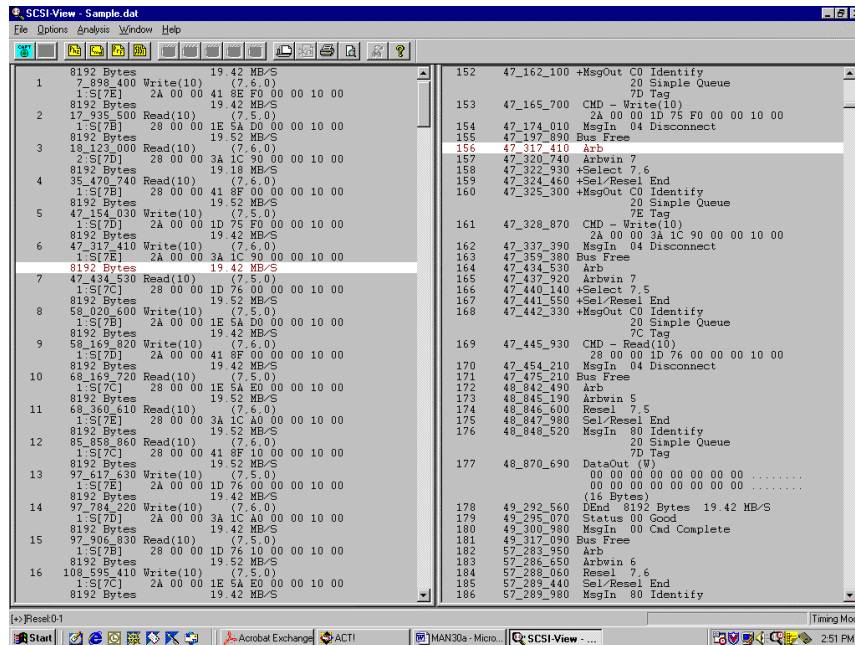

Figure 29

In order to select which window is to be manipulated by the window movement commands, it must first be made to have the current 'focus'. This is done by moving the mouse cursor into the desired window's area and clicking once. The border will then be highlighted for that window.

Any active window can be closed by clicking on the Close button in the upper right corner of the window. In addition, selecting **Window, Close (ALT F7)** will close it.

5.5 Moving Around Analysis Views

In order to move around a current View that automatically scrolling, such as a current Phase and Command View, you must first pause the scrolling of data by moving the cursor to any line in the display and clicking the left mouse button. A highlight bar will appear on that line, and all scrolling will stop. (All SCSI activity will continue to be stored to a file.) Pressing ENTER instead will stop updates with the center line of the display highlighted. Clicking the right mouse button, pressing ENTER or typing the ESC key will resume scrolling. This is not required for Views that are not automatically scrolling, such as Current Performance or any file View.

Once you have paused the scrolling in an analysis window you can move up and down in the window using either the keyboard navigation keys or the mouse. The following navigation keys can be used:

• Page Up, Page Down	Moves the window up/down one screen.
• HOME	Moves View window to the left side.
• END	Moves View window to the right side.
• <CTRL> Home	Moves to the top of the file
• <CTRL> End	Moves to the end of the file.
• Up / Down / Left / Right Arrows	Moves 1 line / column in each direction.
• <	Moves up one command or phase.
• <SH> UP Arrow	Moves down one command or phase.
• <SH> DOWN Arrow	Moves down one command or phase.
• TAB	Moves N commands or phases down
• <SH> TAB	Moves N commands or phases up (N is set in Options, Display Views)
	(Note: TAB and <SH> TAB move +/- one field in Dialogs)
• + / -	In Command Views that are linked to a Phase View, the +/- keys move the linked Phase View through multiple disconnect / reconnect phase blocks for a single command. The status line will display 'RSEL (x of n)', where 'x' is the current block, (starting at 0), out of a total of 'n' blocks.

The following mouse actions can be taken.

On The Horizontal Scroll Bar:

• Click on the left/right arrows at the left/right end of the scroll bar.	Move left/right one line.
• Click to the left/right of the position indicator on the scroll bar.	Move left/right one screen.
• Drag the position indicator left/right.	Move left/right any amount.

On The Vertical Scroll Bar:

• Click on the up/down arrows at the top/bottom of the scroll bar.	Move up/down one line.
--	------------------------

<ul style="list-style-type: none"> Click just above or below the position indicator on the scroll bar. 	Move up/down one page.
<ul style="list-style-type: none"> Drag the position indicator up/down. 	Move up/down any amount.

5.6 Searching Protocol Capture Files

One of the more powerful features of SCSI-View is its ability to search large SCSI-View session files for specific items. This is important because SCSI-View has the capability of capturing very SCSI sessions of up to 42GB in size.

SCSI-View's ability to search and filter captured SCSI activity makes powerful analysis of large capture databases possible without complex trigger set ups.

Line Numbers	
✓	Phase E <u>e</u> nt Number
✓	E <u>e</u> vent Time
✓	Difference <u>T</u> ime
✓	Extended Message
✓	D <u>i</u> splay Data
✓	D <u>i</u> splay ASC <u>I</u> I
	Back <u>L</u> ink to Command
G <u>o</u> to Event Number...	Shift+F2
Find <u>O</u> peration...	Shift+F3
Find <u>P</u> hase Time...	Shift+F4
Find <u>B</u> urst Rate...	Shift+F5
Extract <u>S</u> ession File...	Shift+F8
Change Transfer <u>W</u> idths...	Ctrl+F2
Change Device <u>T</u> ypes...	Ctrl+F7
Set/Remove <u>A</u> nchor	Ins
<u>M</u> arkers...	Shift+F7
Open Data <u>W</u> indow	Alt+D
<u>L</u> ink to Timing View	Ctrl+F1

Figure 30

To initiate a search in any analysis View, first 'focus' on the View by moving the cursor inside that window and left clicking, which will highlight that window's border (click on the Phase View of Sample.dat.) **Click the right mouse button** inside that window (or press **F2**) which will bring up the Popup Operations Menu (Figure 30.)

This Menu displays a wide range of display and search operations that can be applied to each View.

- Go To Event Number jumps to any event number in the capture session file.
- Find Operation searches for a wide range of SCSI Commands, Conditions, Messages and Status values. If the desired search value is not present in either the scrolling Condition or Command list, it can be entered as a specific Message, Status or Command Hex byte value.
- Find Phase Time searches for specific phases and phase duration times.
- Find Burst Rates searches for a specific range of R/W Command, Data Phase burst rates
- Extract Session File creates a smaller .DAT file from between an anchor point (set by placing the cursor on a desired line and pressing **Insert**) and the current cursor position.
- Set / Remove Anchor creates a second cursor that enables Delta time measurements, Print Extractions and Session File Extractions between the Anchor Cursor and the Regular Cursor.
- Markers allows the creation of any number of user defined marker labels in the file.
- Open Data Window opens a second window for viewing all data captured during a data phase. Multiple data windows can be opened and compared by SCSI-View.

The Find Operation dialog screen, (Figure 31), displays the complete set of search choices for this phase level analysis window. Select any desired condition and click on OK to search to the next occurrence of that condition.

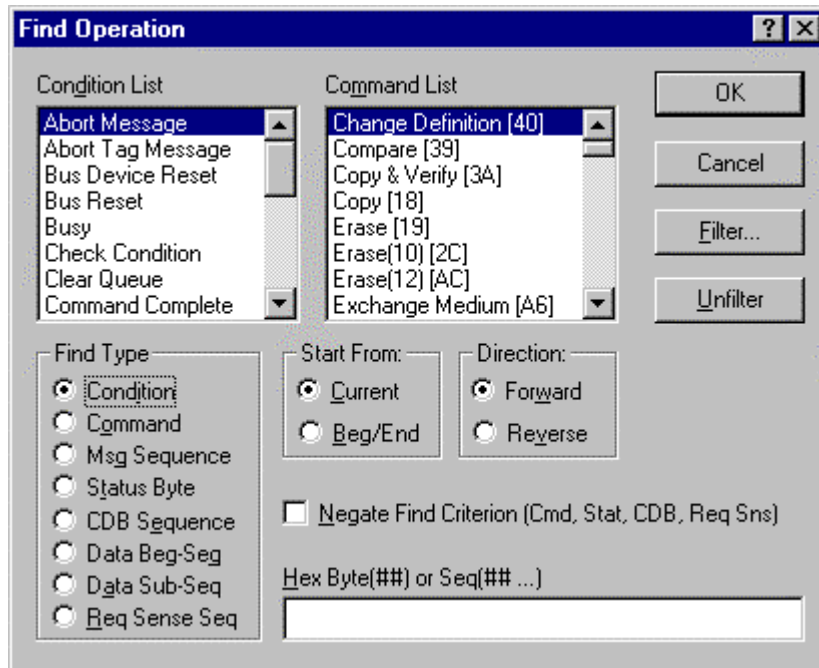

Figure 31

5.7 Filtering Views for Specific Device ID's and LUN's

Any analysis window can be filtered to display only the Device ID and LUN information that you wish to see. (*Analysis windows default to display all ID's and LUN's.*) Note that filtering the displayed information in an analysis window does not affect the information that is captured to a file. All SCSI activity will continue to be captured to file regardless of filter settings. This allows the user to go back later to review and analyze captured SCSI information with any desired ID and LUN filter criteria.

Filter information can be set to a different value for each analysis window. (For example, one window could be set to filter only for events on ID 6, another might be set to filter only for events on ID's 0 and 2.) ID and LUN filters are specified at the time a window is opened. The Filter setup screen, (See Figure 32), displays the complete set of filter choices for that analysis window.

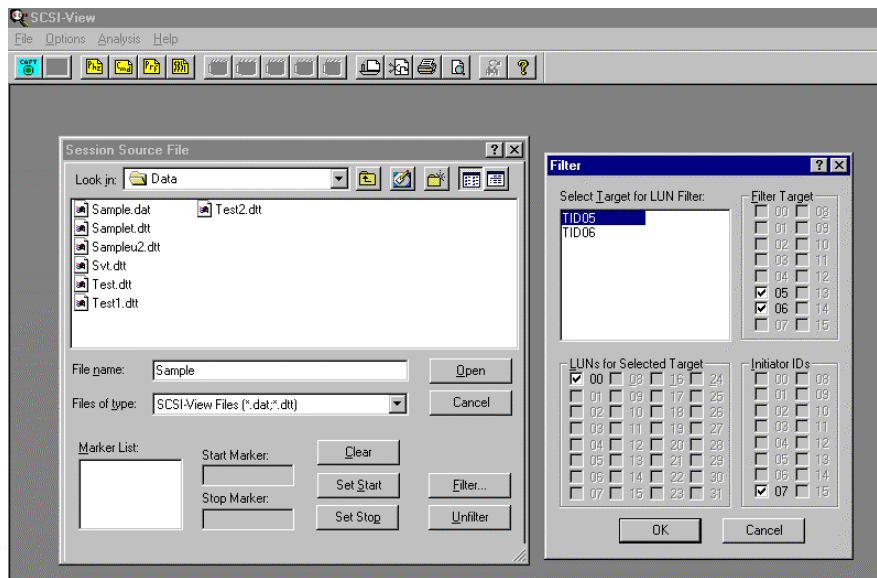

Figure 32

Each filter option is shown as enabled when a \surd appears inside the brackets to its left. Enable / disable any option by clicking on it. When a filter option is enabled, only events with that option's criteria will be displayed. Only the detected IDs and LUNs from the session will be offered for filtering. (This also provides a quick method for determining which devices were active in a session.)

5.8 The Performance View

The Performance window displays a cumulative SCSI performance analysis either for the current capture session, or for previous capture session files.

Close the previous Command and Phase Views by choosing Window, Close All from the top menu bar. To open a Performance View for the sample session, select Analysis, File Performance, from the main menu. The file selection dialog will then display. Select the file `sample.dat` from the file list and click on OK. A SCSI performance analysis window, (Figure 33), for the sample session will then appear and calculate the cumulative performance statistics for that session.

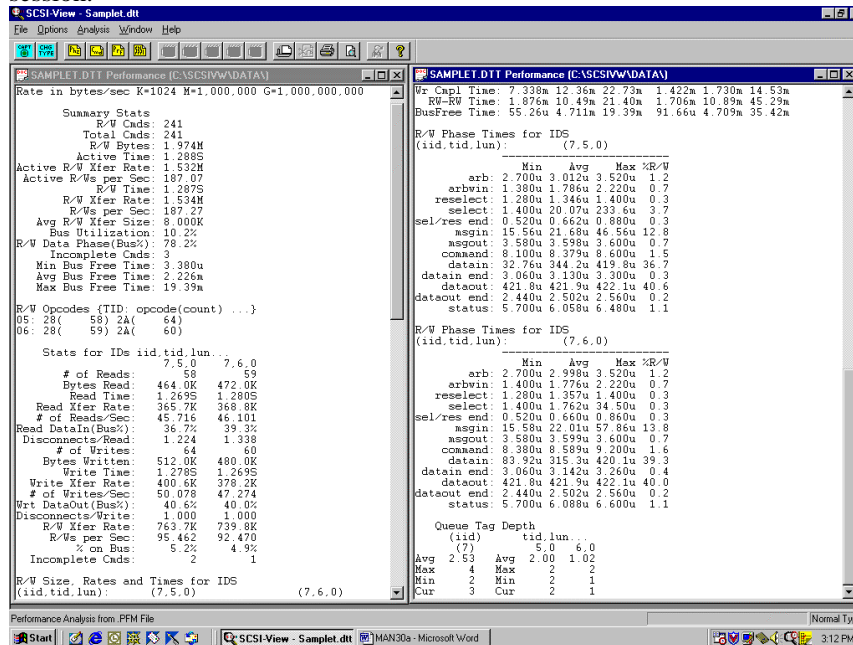

Figure 33

The Performance View is longer than the display screen. Use the up and down page keys to view the various performance calculations. (Figure 33 shows two Views of the same session scrolled to different parts of the analysis.)

See section 6.1, on page 89, for a detailed description of each performance item.

5.9 On line HELP (F1)

SCSI-View has extensive on line help, which is available at any point in its operation. Help includes complete descriptions of every Phase, Command and Performance View display item and 'how to use' instructions for each feature. Press F1 for a complete help description of the current displayed analysis View or menu item. For a more structured on line description see the **Help, Index** menu item for a complete hypertext linked description of how to use SCSI-View.

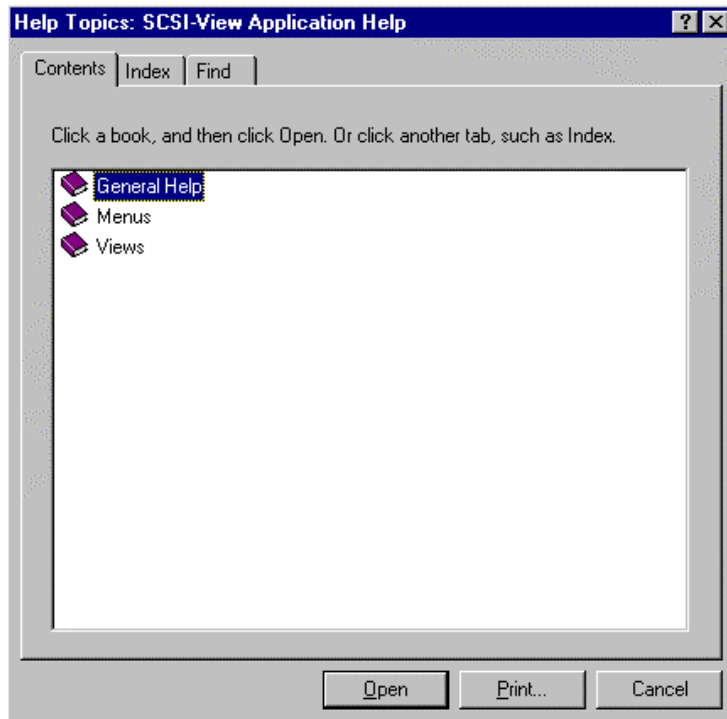

Figure 34

5.10 Exiting SCSI-View (ALT-X)

(Captured SCSI activity is automatically saved to a file)

You can exit SCSI-View at any time, and your captured SCSI activity, along with your current system configuration, will automatically be saved to disk.

Using the mouse, select **File, Exit**, (or click on the **Alt-X** entry on the status line). From the keyboard, type **<ALT>X**. SCSI-View will save all current files and exit. Or simply click on the **CLOSE** button in the upper right hand corner of the SCSI-View window.

6 Detailed Feature Descriptions

In This Chapter:

6.1 Protocol Analysis	69
6.1.1 Phase View	69
6.1.1.1 Time Stamp.....	70
6.1.1.2 Operation Type.....	70
6.1.1.3 Initiator, Target ID's	72
6.1.1.4 Operation Parameters	72
6.1.1.5 Data Burst Rate	72
6.1.1.6 Number of Data Bytes Transferred	72
6.1.1.7 Open Data Window	72
6.1.2 Linked Phase and Timing Views	74
6.1.3 Command View	75
6.1.4 Linked Command Views and Phase Views.....	79
6.1.4.1 Following Multiple Disconnect Command Threads	80
6.1.5 Filtering Protocol Views by ID and LUN.....	81
6.1.6 Searching Command and Phase Views.....	82
6.1.6.1 Go To Event Number (Includes Go To Marker).....	82
6.1.6.2 Find Operation	83
6.1.6.3 Find Phase Time	84
6.1.6.4 Find Burst Rates.....	85
6.1.6.5 Command View Popup Search Operations.....	85
6.1.6.6 Goto Command Number.....	86
6.1.6.7 Find Command	87
6.1.7 Setting and Using Markers.....	87
6.2 Performance Analysis	89
6.2.1 Performance Analysis Sections.....	90
6.2.2 Performance Measurements - Detailed Descriptions	91
6.2.2.1 Summary Stats	92
6.2.2.2 Stats for IDs by Nexus (iid,tid,lun)	93
6.2.2.3 R/W Size, Rates and Times for IDS.....	94
6.2.2.4 R/W Phase Time for IDS (min., avg., max.)	95
6.2.2.5 Queue Tag Depth for IDS.....	96
6.2.3 Filtering Performance Views by ID and LUN	97
6.3 Timing Waveform Analysis	99
6.3.1 Normal and Recirculate Capture (SV-8160 / SV-3000)	99
6.3.2 Enabling Timing Capture Mode (SV-1620 / SV-1600).....	100
6.3.3 Capture Options for Timing	101

6.3.3.1	RAM Buffer for Capture (Normal Mode).....	102
6.3.3.2	Capture All Data	102
6.3.3.3	Triggers.....	102
6.3.4	Timing View	103
6.3.5	Timing Popup Operations.....	104
6.3.5.1	Show / Remove Event Numbers	104
6.3.5.2	Show / Remove Event Time.....	104
6.3.5.3	Absolute / Difference Time	104
6.3.5.4	Remove / Display CTRL, DATA and MISC Signals	104
6.3.5.5	Bit 1/0 - Waveform Display	104
6.3.5.6	Set 1 (high) to Logical True / False.....	105
6.3.5.7	More Display Options.....	105
6.3.5.8	Enable Back Link to Phase	105
6.3.5.9	Go To Event	105
6.3.5.10	Find Condition.....	106
6.3.5.11	Extracting Smaller Files, Delta Time Measurement	109
6.3.5.12	Markers	109
6.3.6	Linked Phase - Timing Views.....	110
6.3.6.1	Linking to Specific Command, Message and Data Bytes.....	110
6.3.6.2	Enable Back Link to Phase (Popup Option)	111
6.3.7	In Case of Problems.....	111
6.3.7.1	Timing mode requires the hardware to be enabled for timing. 111	
6.3.7.2	Slow Current Window Updates, Buffer Overflow	111
6.4	Bus Inspector View	113

6.1 Protocol Analysis

The **Analysis** windows are used to display current or previously captured SCSI protocol activity. Multiple protocol windows can be open at one time. For example, multiple protocol windows can be used to compare current and previous SCSI activity, to display current SCSI activity filtered for different SCSI ID and LUN values and to display SCSI activity at different levels of detail.

6.1.1 Phase View

The Phase View presents a Phase level, fully detailed, display of SCSI protocol activity. (Figure 35)

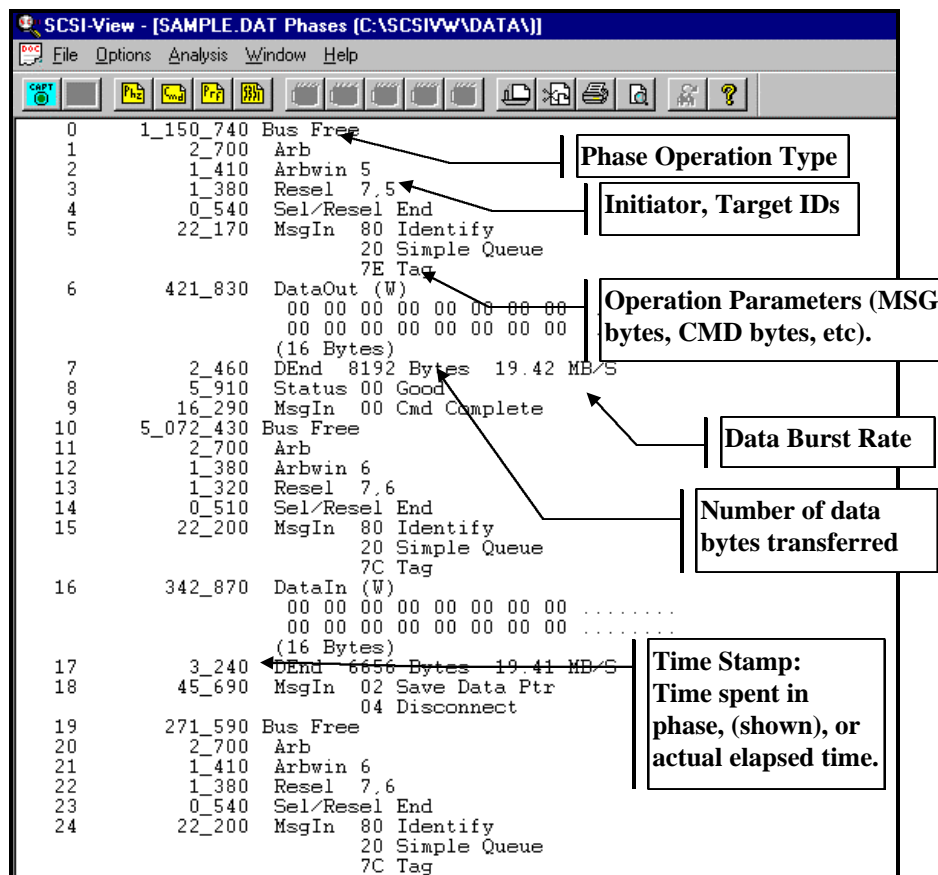

Figure 35

To open a Phase View, chose **Analysis, File Phase** or **Analysis Current Phase**. The **Analysis, File** options display information for previously captured files. The **Analysis, Current** options display live activity for protocol captures in process.

6.1.1.1 Time Stamp

Shows the time spent in each operation, (difference time), or alternatively the elapsed time from the beginning of the session to the time that the Phase change occurred. The time display mode can be selected from the Popup Options Menu by selecting either Absolute Time or Difference Time.

The SV-1620 and SV-1600 analyzers have two modes of capturing SCSI activity: Phase mode and Timing mode. The SV-8160 and SV-3000 only capture in Timing mode. When capturing in Phase mode, users can select whether data out phases are time stamped on REQ or ACK in the **Options, Capture Options** menu (**F4**.) All other phases are time stamped at their initial edge, (ARB, SEL, RESET etc.)

On the SV-8020/8000 analyzers, all phases that involve byte transfers are time stamped as beginning on the leading edge of REQ, (for IN operations), or ACK (for OUT operations.)

The Time Stamp is formatted as '**ssss.mmm_uuu_nnn**'. Leading zeros are suppressed

ssss **Seconds**
mmm **Milliseconds**
uuu **Microseconds**
nnn **Nanoseconds**

If the time value has not reached 1 second, full timing resolution is shown to the nanosecond level. Once seconds are displayed, the nanosecond level may be dropped, depending upon the display width selected by the user. See **Options, Display Views** to set different Phase, Command and Performance display text widths. (Note: SCSI-View samples phase transitions at a 10ns rate.)

6.1.1.2 Operation Type

Shows what type of SCSI operation occurred. Phase operations include:

• Reset	Reset line is asserted
• Bus Free	No SCSI activity. (BUSY & SELECT are both false)
• Arb	One or more devices has begun bus arbitration

• Arb Win	One device has won arbitration
• Select	Initiator begins target selection
• Reselect	Target begins re-selection
• Sel/Rsel End	Target has responded to select, and Initiator has just released SEL. Time stamped on the release of SEL.
• Msg In/Out	Message in or out phase, with message byte(s) displayed
• CMD(6, 10 or 12)	Command phase, (6, 10 or 12 byte command), with command bytes displayed
• Data In/Out	Beginning of Data in or out phase. (Time stamp on 1st REQ or ACK of 1st byte)
• Dend	End of Data Phase. (Time stamp is for last byte transferred) Data transfer byte count and burst data rates are displayed. If data capture was enabled, show the captured bytes. Note: <u>Data is always captured for non-read/write command data phases</u> , such as Inquiry, Mode Select, etc. To enable data capture for read/write command data phases, use the Options, Capture Options dialog. The first 8, 32 or 256 bytes of each read/write data phase will then be captured and displayed.
* (To the left of data)	Indicates a parity error in captured data (timing mode captures only).
• Hung	Indicates capture was halted by the user, (ALT-C), when the bus was in the middle of a data phase. (Typically during a hung bus.) The number of bytes transferred up to that point will be displayed. This replaces Dend for interrupted data phases.
• Status	Status Phase, with status byte displayed.
• + (to left of op. type)	Attention line asserted. (Included with any of the above Operation lines) Note: Attention is <u>latched</u> by the SCSI-View hardware and is displayed with the next phase. It will continue to be displayed with each phase until it is released. (While attention is typically released prior to the Message Out phase, SCSI-View will display it with that phase since it was active just prior to MsgOut.)
• SCAM Select	SCAM protocol Select phase
• Synchronize	SCAM protocol Synchronize phase
• Isolate	SCAM protocol Isolate phase (Includes SCAM data

	transfer)
• Assign ID	SCAM protocol Assign ID phase
• SCAM End	End of SCAM protocol

6.1.1.3 Initiator, Target ID's

Shows the Initiator, and optionally the Target ID's for the operation. '**Sel 7,0**' indicates that Initiator ID7 is selecting target ID0.

6.1.1.4 Operation Parameters

Displays parameter bytes, and their decoded meaning when possible, for the current operation. This includes decoding of message byte sequences such as: Command Complete, Disconnect, Tagged Queue Operations, Synchronous Negotiation results And Wide Negotiation results.

6.1.1.5 Data Burst Rate

Calculates the data transfer burst rate for this operation.

6.1.1.6 Number of Data Bytes Transferred

Shows the number of bytes transferred in the preceding data phase operation. (**Phase mode captures.**)

In **Phase Views of Timing Mode Captures involving intervals**, the last line of the data display following the DataIn or DataOut Phase contains an indication of the amount of data bytes captured. The format for this display is shown below:

([+]**SS:II**[**R**] **nn** Bytes)

Fields in [] square brackets are optional.

+ means capture started from an interval boundary.

SS Capture size in bytes.

II Interval size in bytes.

R means the capture was repeated on interval boundaries.

nn Amount of data phase bytes actually captured.

6.1.1.7 Open Data Window

SCSI-View limits the data display in Phase Views to 32 bytes. This option allows the user to display the complete data phase capture in a separate window. The cursor must be positioned on a data phase for this option to be used.

6.1.1.7.1 Data Window Popup Options

Pressing F2 or the right mouse button while in a Data Window brings up this popup window. Options are provided to jump to any byte offset, find a byte pattern and to compare two data windows.

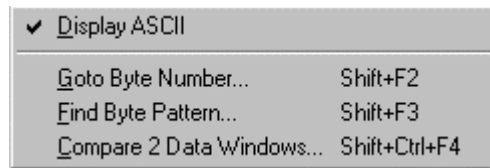

Figure 36

6.1.2 Linked Phase and Timing Views

SCSI-View can also display the detailed Timing for SCSI protocol sequences. Double clicking on a SCSI phase event in a Phase View will bring up a linked Timing View in a manner similar to double clicking on a command in a Command View brings up a linked Phase View. Movement of the cursor from one phase to another in the Phase View will cause a linked movement in the Timing View. (This feature is included with the SV-8160, SV-3000, SV-1620 and SV-1600 analyzers.)

The Timing View displays either absolute or difference time stamps for each signal transition. Each new line in the Timing View represents a transition on one or more of the SCSI Bus signals or a change in one of the external input signals. (**Right Click** the mouse or press **F2** to bring up the options box for selection of display and time formatting.)

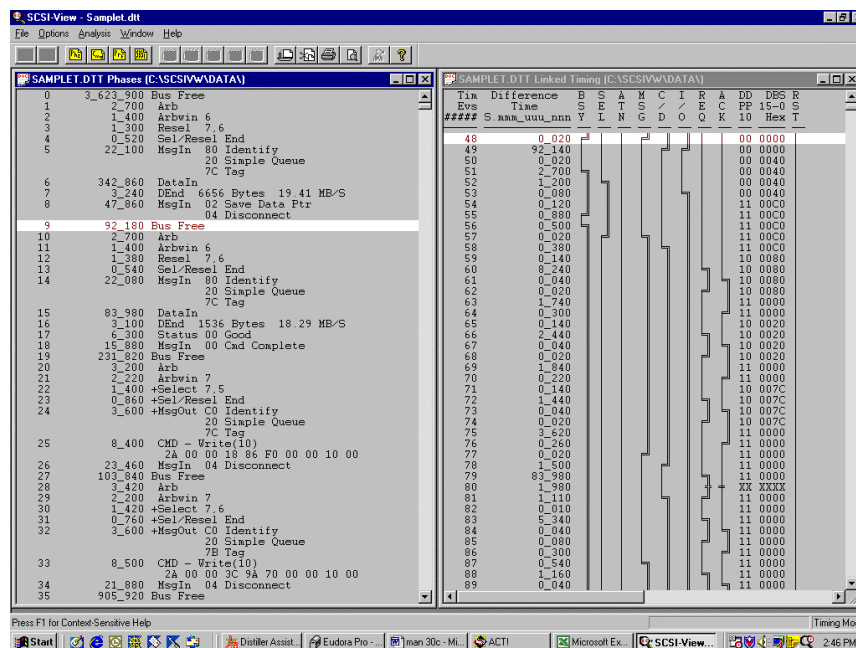
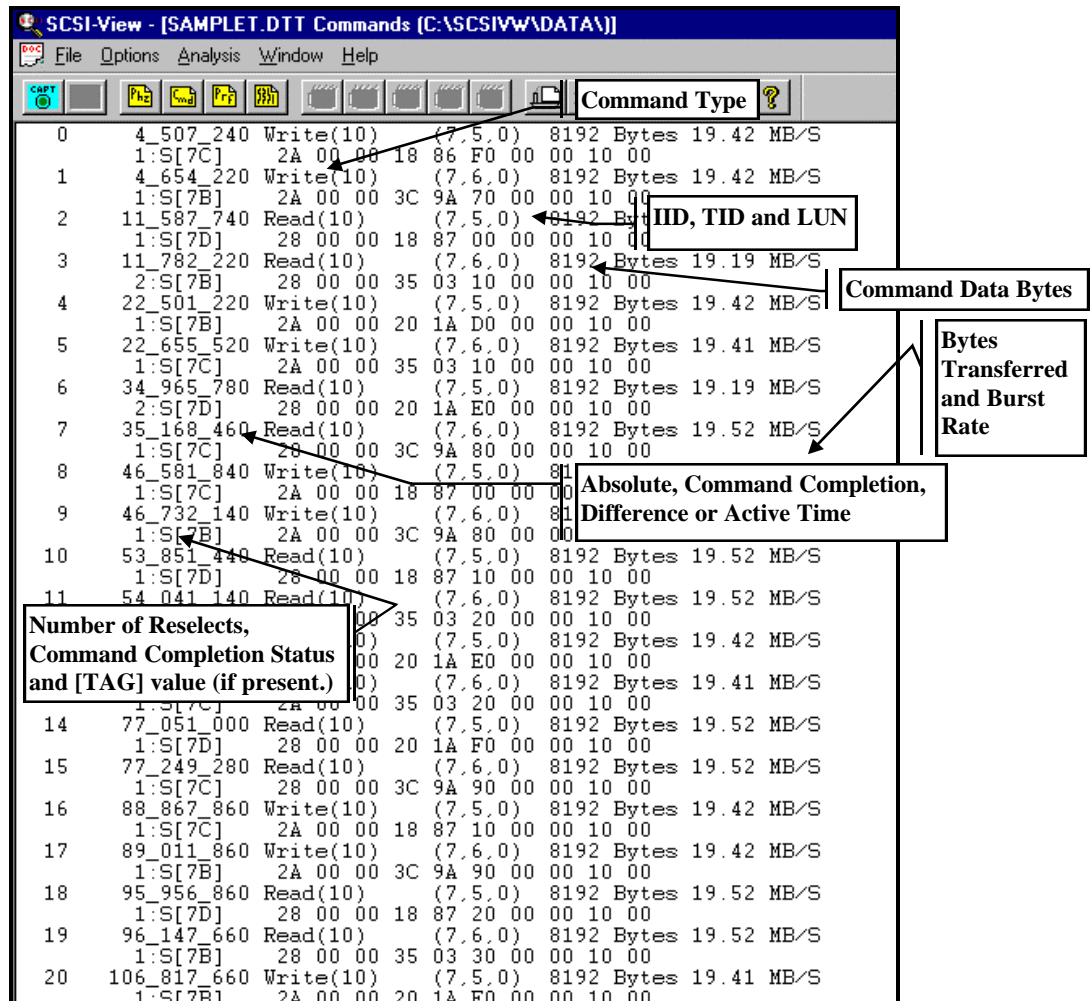

Figure 37

See Section 6.3 on page 99 for a detailed description of the Timing View.

6.1.3 Command View

The Command View condenses each complete command operation, from the initial arbitration to the final bus free following a 'command complete' message, into a single line display. Figure 38 shows a typical command level detail display. CDB values for each command can be enabled / disabled for display through the Command Popup Operations window. (**Right click** the mouse, or press **F2** inside the Command View to bring up the Popup window.)



Command View
Figure 38

To open a command View chose **Analysis, File Command** or **Analysis Current Command**. The **Analysis, File** options display information for

previously captured files. The **Analysis, Current** options display live activity for protocol captures in process.

NOTE: Only one **Current Command** View may be open at one time. (Multiple **File Command** Views are allowed.) **Current Command Views are only active for non-continuous file capture sessions** (non 'wrap around files). See the **Options, Capture Options** dialog to enable /disable the continuous capture mode.)

Completion Status codes are displayed for each Command just to the right of the colon following the number of re-selects for the command. These codes are:

- **I** Incomplete
- **S** Success
- **C** Check Condition
- **B** Busy
- **T** Terminated
- **L** Successful Linked Command

Like the Phase View, the time stamp for each command can be displayed in several formats. (See the Time Stamp description on page 70 for a description of the time format.) The following time stamps can be selected from the Popup window (**Right Click** or press **F2**):

- Absolute Time Absolute time of the initial ARB of the command.
- Completion Time Total **elapsed time** for the command to complete. This covers the time from the initial ARB to the BUS FREE following Command Complete, including all disconnect - reconnect sequences.
- Difference Time Time from the ARB at the start of the command to the ARB at the start of the following command.
- Active Time Total time the command was **active on the bus**. This covers the time on bus from the initial ARB to the BUS FREE following Command .

When any File Command View is started for the first time on a particular capture file, SCSI-View also begins building a navigation index file for that capture file. The status line will indicate this with the 'Building Index' message. For very long capture files this may take some time, but the file can be viewed and navigated up to the point of index completion while the build is in progress. Subsequent openings of the Command View for this file will not require a new index build. Index files have the extension '.IDX' and the same name as the

capture file. When deleting capture files, also remember to delete the corresponding '.IDX' files.

6.1.4 Linked Command Views and Phase Views

Double clicking on any command in the Command View creates a new linked Phase View, with the cursor highlighting the first ARB of that command block. Cursor movement in the Command View is immediately reflected in the linked Phase View. (Figure 39), shows the result of double clicking on a Stop/Start command in the Command View. The linked Phase View is centered on the initial ARB for the same command.

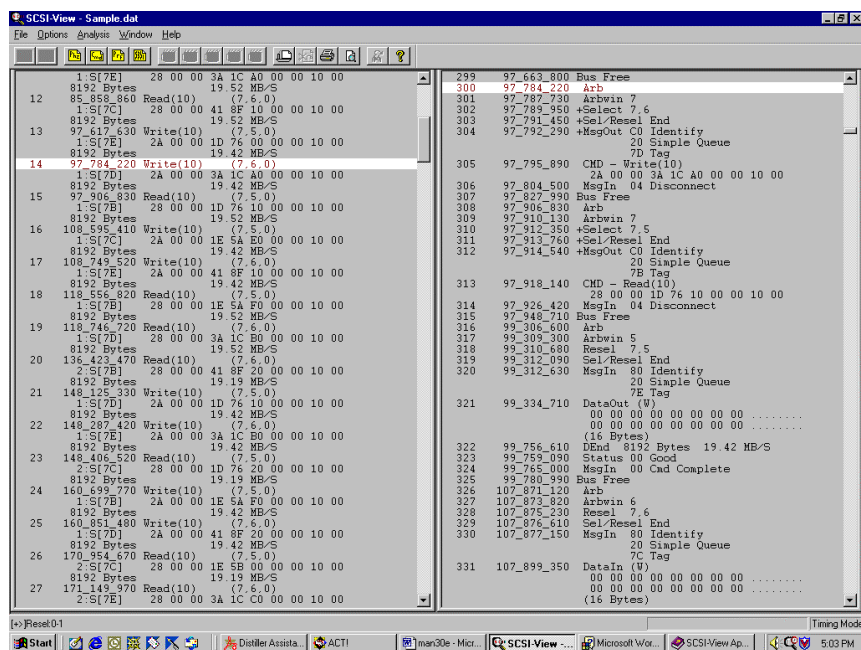

Linked Command and Phase Views
Figure 39

Only **File, Command Views** can be linked to their Phase View. If **Current Views of Command and Phase** are desired, open separate Current Command and Current Phase Views.

In Command Views that are linked to a Phase View, the +/- keys move the linked Phase View through multiple disconnect / reconnect phase blocks for each command. Click on the desired command to highlight it, and the status line will then display **'RSEL (m of n)'**, where 'm' is the current block, (starting at 0), out of a total of 'n' blocks. If the number of blocks is greater than zero, the + and - keys will navigate forward and backward along the disconnect - reconnect chain for that command.

As with the linked Phase and Timing the Phase View is synchronized to its parent linked Command View in both directions. Any movement in the Command View will be immediately reflected in the linked Phase View, and movement in the Phase View will be synchronized to the linked Command View parent.,

To move the Command View to the same point as the Phase View, note what the event number is for the phase being displayed, and then use the **Goto Command** Popup option to jump to that phase number in the Command View.

6.1.4.1 Following Multiple Disconnect Command Threads

SCSI-View also allows users to **follow the threads of single commands that are separated by multiple Disconnect - Reselect sequences**. In the case of the previous linked command example in Figure 39, the **'Write (10)'** command on line 14 shows that it has 1 Reselect and completed with satisfactory status (1:S). The linked Phase View shows the initial ARB and following phases for the first part of this command. The status line in the lower left of the View shows that we are positioned on reselect 0 of 1 (i.e. the first part of the command prior to disconnecting). Pressing the '+' key will move the linked Phase View to the next reselect for this command. (The '-' key will return the Phase View to the initial part of the command.) In this manner users can navigate commands that may be split in to many pieces throughout a capture file, as is typical with very long data read / write transfers.

6.1.5 Filtering Protocol Views by ID and LUN

Both File Phase and File Command Views can be filtered to display only selected SCSI IDs and LUNs. Clicking on the **Filter** button in the file selection dialog brings up the Filter dialog shown in Figure 40.

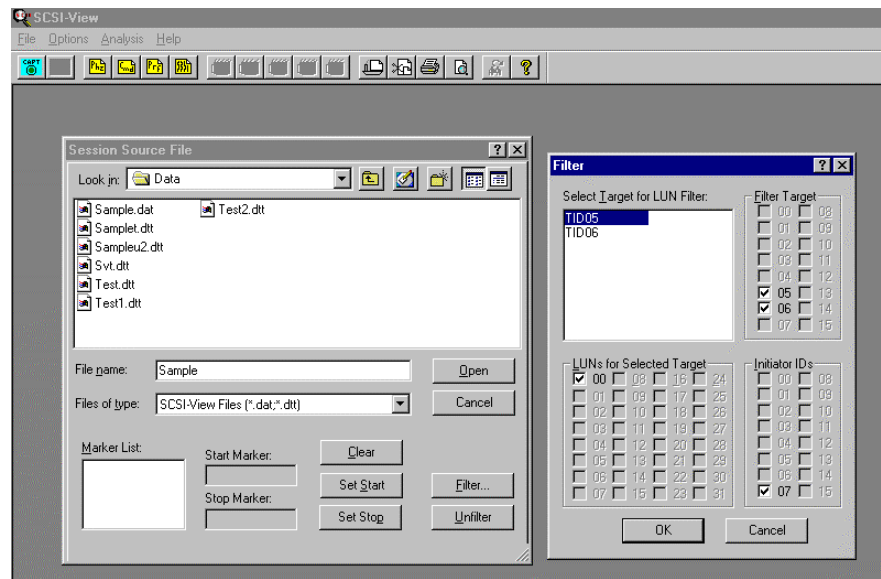

Figure 40

Only IDs and LUNs that were present in the session will be shown. Clicking on the bracket area next to each ID and LUN toggles its enable on and off. (X signifies which IDs and LUNs will be displayed.)

Multiple Phase and Command Views can even be opened at the same time with different filters to view a session from different perspectives.

Only **File** Phase, Command and Performance Views can be filtered by ID and LUN. **Current** Phase, Command and Performance Views can only be viewed in the unfiltered mode.

Note: Since Bus Reset effects all IDs, and the Device Reset Command Message impact LUNs of the ID receiving the message, they will always be shown regardless of filter values.

6.1.6 Searching Command and Phase Views

Command and Phase Views can be searched using a wide range of options, including Commands, Messages, Burst Data Rates and Phase times. The search options can be reached via the Popup Menu operations in the Command and Phase Views. (**The Popup Menu Operations are activated by right clicking the mouse** in the applicable Command or Phase window, by **pressing F2** or by selecting **Options, Popup Operations**.) Figure 41 shows the search options available in Phase View.

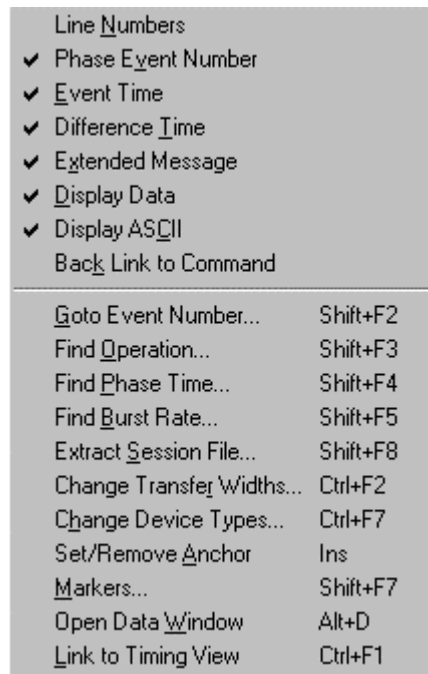

Figure 41

All search operations can be repeated by typing **<ALT> n** or by clicking on **FindNext** on the lower status line.

6.1.6.1 Go To Event Number (Includes Go To Marker)

Jumps either to a specified Phase event line number, or to any of the user defined markers shown in the list box.

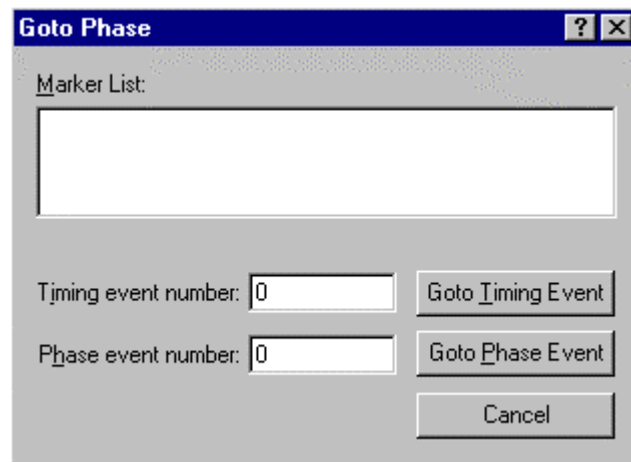

Figure 42

6.1.6.2 Find Operation

The **Find Operation** dialog can be searched for a wide range of SCSI Commands, Conditions, Message Values and Status bytes. If a value is not present on either of the scrolling Condition or Command lists, Specific Message, Status, Command and Request Sense hex byte sequences can be entered directly.

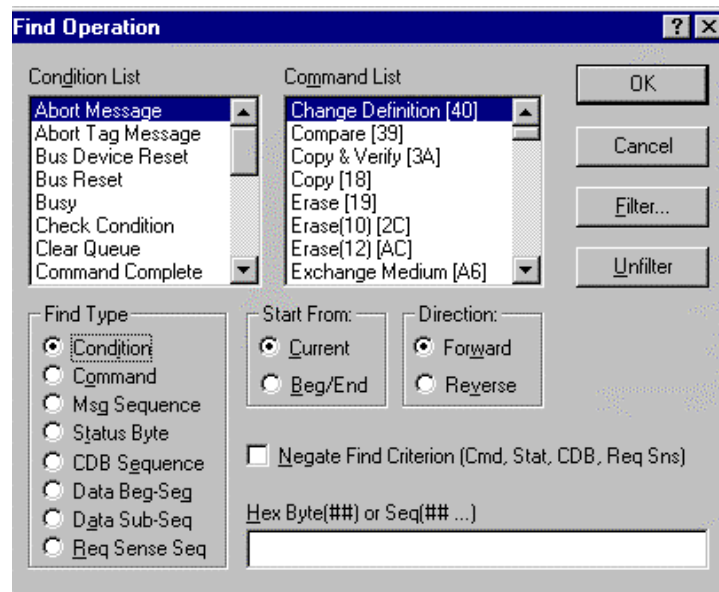

Figure 43

In addition to the Condition and Command values available in the list box, individual HEX byte values can be searched for by using the Find Message, Status, CDB, Data Phase Sequence and Request Sense check boxes. Except for Status, these searches can be for multi-byte HEX sequences. Up to 16 bytes may be entered for data phase sequences. **Find Data Beg-Seq** only searches from the beginning of a data phase while **Find Data Sub-Seq** slides the search sequence mask through the captured data phase data one byte at a time looking for a match. All multi-byte HEX sequences are entered separated by spaces. Individual nibble values can be wild-carded by entering the '?' character. Trailing bytes not entered for a multi-byte sequence (such as for a CDB) will be automatically wild-carded.

Find Req Sense Seq searches on up to three request sense bytes, (The Sense Key (byte 1), the Additional Sense Code (Byte 12), and the Additional Sense Code Qualifier (byte 13). If the last one or two bytes of this three byte sequence are not specified they will be automatically wild carded. In addition, each byte can be wild carded on a nibble basis by typing a '?' for any digit. For Example: **To search on Unit Attention** in the sense key, enter '?6' for the sequence. **To search on End of Data Detected** in the additional sense codes, enter '?? 00 05.'

6.1.6.3 Find Phase Time

Find Phase Time searches for specific phases and phase duration times. The search can be started from the current location, or from the beginning of the file. This search can also be filtered by ID and LUN. Repeat the search by typing **<ALT> n** or clicking on **Search Next** on the bottom status line.

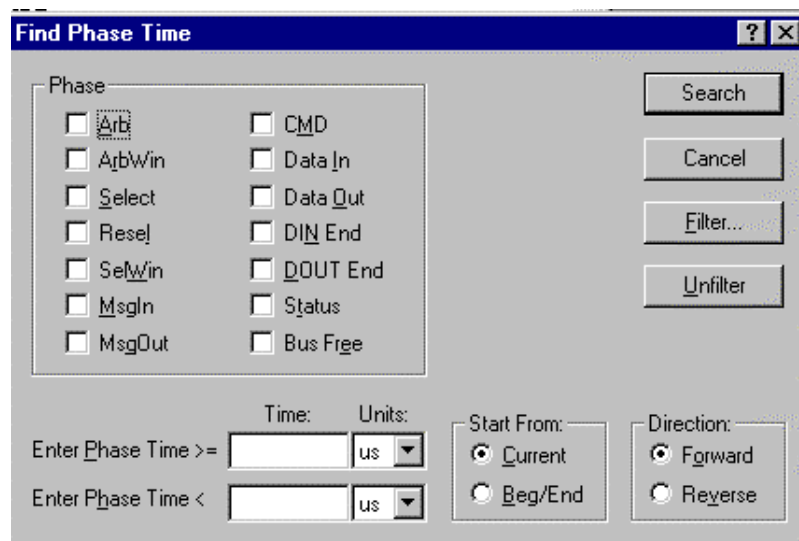

Figure 44

6.1.6.4 Find Burst Rates

Find Burst Data Rate searches for a specific range of Data Phase, R/W operation, data burst rates. \the search can take place from the current location or from the beginning of the file. This search can also be filtered by ID and LUN. Repeat the search by typing **<ALT> n** or clicking on **Search Next** on the bottom status line.

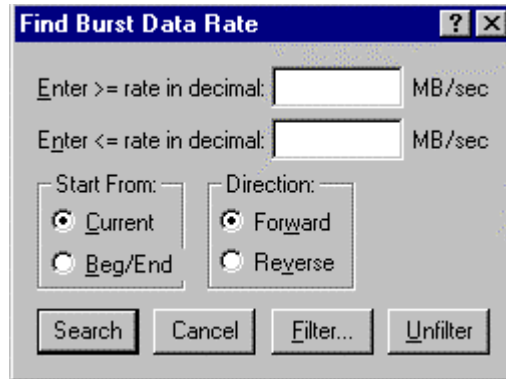

Figure 45

6.1.6.5 Command View Popup Search Operations

Right Clicking in a Command View brings up the Command Popup Menu. (**The Popup Menu Operations are activated by right clicking the mouse** in the applicable Command window, by **pressing F2** or by selecting **Options, Popup Operations**.) Figure 46 shows the search options available in Command View.

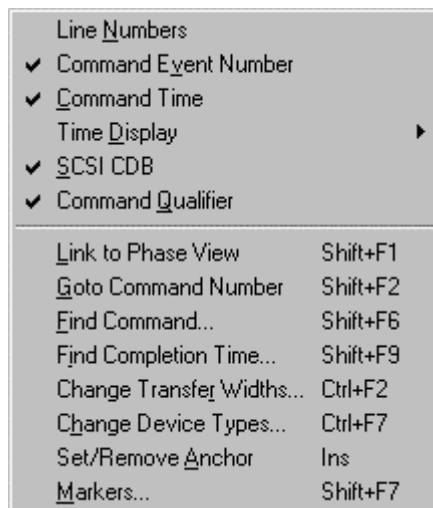

Figure 46

6.1.6.6 Goto Command Number

Goto command Number jumps to a specified Command line number, to a specified phase event number or to any of the user defined markers shown in the list box. Double click on a marker to jump to it.

Choosing an event number for a phase anywhere within a command will position the command cursor at that command.

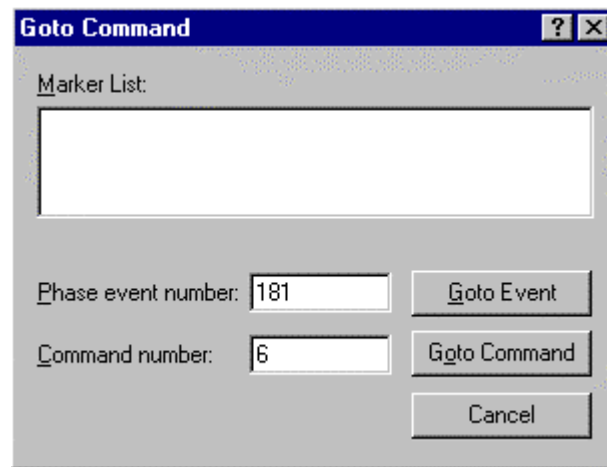

Figure 47

6.1.6.7 Find Command

Find Command searches for the next instance of the selected command. Select the desired command from the scrolling list box and check either **Current Position** or **Beginning of File** for the start of the search. Use the **Find Nth Command Count** box to find the nth occurrence of a command. (Find command defaults to N=1.)

Find Command can also search for incomplete commands or commands that end due to session termination, Busy status and check conditions. Find CDB Sequence allows searching for any command byte sequence, including wildcards on any hex byte nibble with the '?' character.

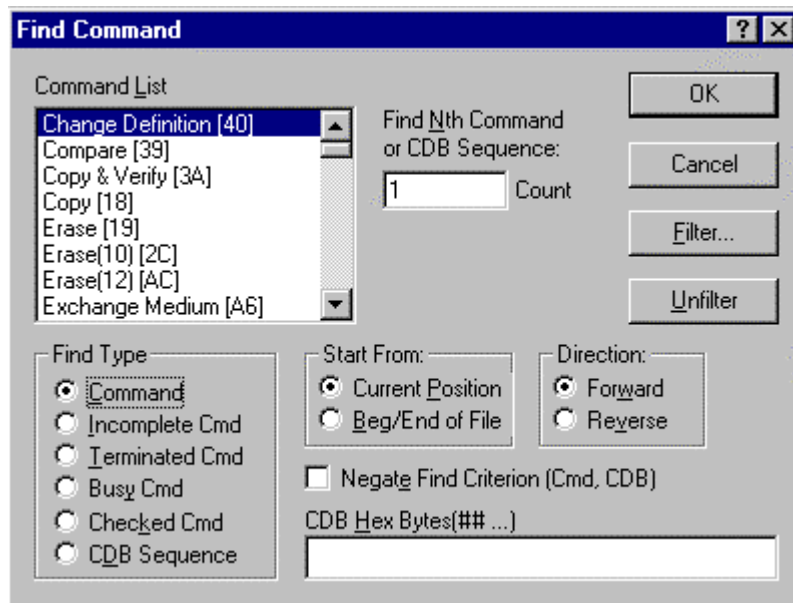

Figure 48

6.1.7 Setting and Using Markers

The Marker definition dialog can be accessed from the Phase and Command View by bringing up the Popup Menu (**right click the mouse** in the phase or command window or press **F2**) and choosing the **Markers** option.

The Markers dialog, Figure 49, creates and edits location markers within the session file. UP to 16 markers can be defined for each session file. Markers can be changed or deleted using this dialog. Markers can be used to do the following:

- Set the limits for display in Command or Phase View when defined as start/stop markers in the file open dialog.

- Set the limits for analysis in Performance View when defined as start / stop points in the file open dialog.
- Set the limits for printing when defined as start / stop points in the file open dialog.
- Jump to any defined marker using the Goto Event or Goto Command Popup operations.

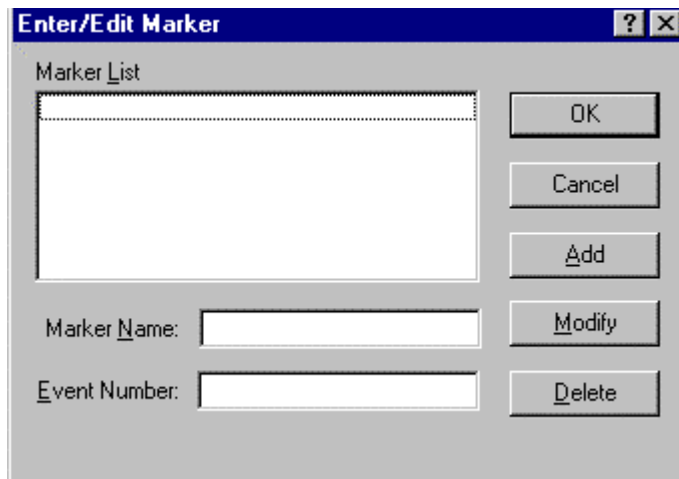

Figure 49

Markers can be defined in Phase and Command Views. If a line in the Phase or Command View is highlighted when this dialog is entered, the line number for that line will be entered as the event number.

Note: When Start and Stop markers are used to define the limits of a Command View, the View will start with the first command whose initial ARB is later than or equal to the Start Marker. It will end with the last command whose initial ARB and subsequent Bus Free are before or equal to the End Marker. (The end marker is located on the subsequent Bus Free.) End markers that are set inside of a command will cause that command to drop off the Command View.

6.2 Performance Analysis

The Performance window displays SCSI system performance analysis either for the current capture session, or for previous capture session files. This analysis includes overall system statistics, individual device statistics, (including data rates and phase times), and tagged queuing performance data. This information is useful for tuning, benchmarking and debugging of a wide range of SCSI systems, including RAID Arrays, Tape Drives and Disk Drives.

To open a performance window, select **Analysis, File Performance, or Analysis Current Performance** from the main menu. A SCSI performance analysis window, (Figure 50), will then appear and calculate the cumulative performance statistics for the selected session. The **Analysis, File** options display information for previously captured files. The **Analysis, Current** options display live activity for protocol captures in process.

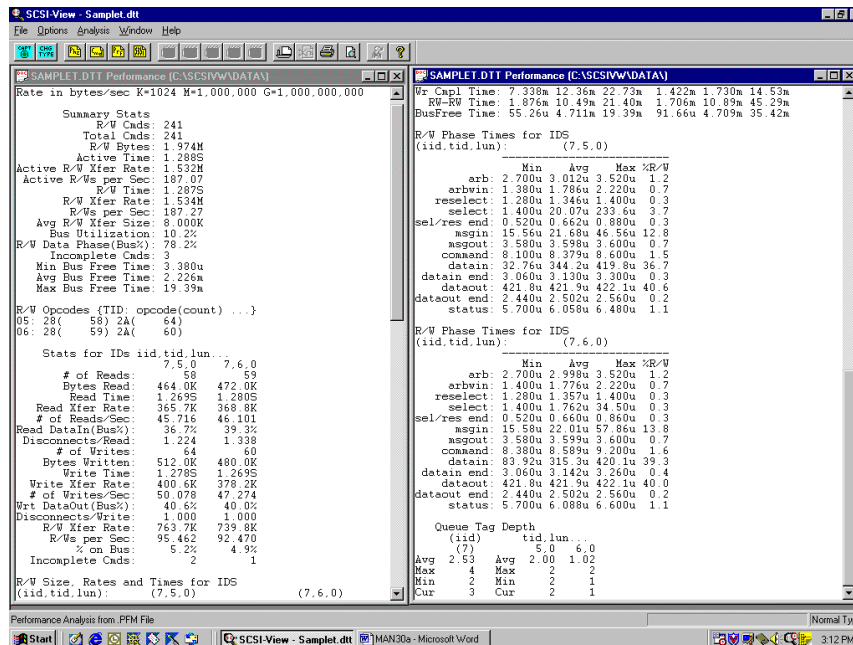

Figure 50

If **File Performance** is chosen, a file dialog will appear. The starting and end points for performance analysis can also be chosen by selecting **Start** or **Stop Markers** in the file dialog. Setting start / stop markers in performance allows the user to include only SCSI activity that is desired for the performance calculations. These markers are set up with the **Markers** Popup dialog while in a protocol window.

Unusual performance numbers, such as for phase times and burst rates, can also be searched for in the Phase View with the **Find Phase Time** and **Find Burst Rate** Popup search dialogs. (Use the **Right Mouse Button** or **F2** while in Phase or Command Views to activate the Popup menu.)

6.2.1 Performance Analysis Sections

Summary Stats, (All Devices)

This section shows overall statistics for the session for all devices combined.

R/W Opcodes, (All Target Devices)

This section displays for each target ID, each R/W Opcode HEX value and the number of times that Opcode has appeared in the capture file.

Stats for IDs, (ID Specific)

This section shows rate and count statistics for each device nexus. The heading '(iid,tid,lun),' refers to the initiator ID, target ID and target LUN. An entry of '7,1,0' refers to initiator ID7, target ID1 and target LUN 0.

R/W Size, Rates and Times for IDs , (ID specific)

This section displays Read / Write operation sizes, Connect Rates (bytes/total of all phase times for the operation), Burst Rate (bytes/data phase time), R/W Completion times and Bus Free times. All times are shown as Minimum, Average and Maximum.

R/W Phase Times for IDs, (ID Specific)

This section shows the time spent in each SCSI phase. This time is measured from the beginning of the listed phase to the beginning of the following phase. All times are shown as Minimum, Average and Maximum. **Phase time percentages** of each device's active, on bus time are also shown.

Tagged Queue, (ID Specific)

This section shows Max, Min and Average Tagged Queue depth for every initiator and target device on a per ID basis.

6.2.2 Performance Measurements - Detailed Descriptions

The following terms are used in this section:

- Total Elapsed Time: Total time from beginning of first active phase to beginning of last phase.
- Command Block: The phase block beginning with ARB and ending with Bus Free after command complete.
- R/W Command: Data Command Read / Write transfers. (Does not include non R/W command data phases)
 - Burst data rate: Rate of data transfer while in data phase for R/W commands only.

The Performance View performs statistical and factor of merit analysis for SCSI R/W activity. The analysis is performed on a complete capture file or one bounded between start and stop markers and by any filter constraints.

The performance analysis is accomplished by traversing the session file and calculating all performance values incrementally. The display is updated roughly every half second. All R/W data transfer calculations and counts in Performance are included if and only if the R/W command had been completed by returning a command complete message. R/W commands are defined for the following opcodes:

Note: For a particular target ID, **the default data transfer width will be used to determine the actual byte count, the data rate, and the bytes captured.** If there has been a Bus Reset, a Bus Device Reset on the target, or a Wide Negotiation with the target, then the new negotiated width determines the byte count, rate and byte output for all points after the negotiation.

Note: If a performance run was based on an incorrect target default data transfer width, and a .PFM file was created, then the .PFM file must be deleted, the target's default data transfer width changed and the performance run be calculated again. (.PFM files contain the computed performance statistics for a corresponding .DAT or .DTT file).

R/W data phase transfer calculations in Performance are calculated only for the following commands:

0x08	Read(6)	0x2F	Verify(10)
0x0A	Write(6)	0x3D	Update Block
0x0B	Slew and Print	0x3E	Read Long
0x0F	Read(6) Reverse	0x3F	Write Long
0x13	Verify (16)	0x41	Write Same
0x28	Read(10)	0xA8	Read(12)
0x2A	Write(10)	0xAA	Write(12)
0x2D	Read Update Block	0xAE	Write and Verify(12)
0x2E	Write and Verify	0xAF	Verify(12)

Table 1

Users may add to and delete from the Read / Write command list used by performance with the **Options, Define Read/Write Opcodes** dialog. This determines which commands are included in Performance View calculations, and which commands will display rate information in the Phase and Command Views.

6.2.2.1 Summary Stats

R/W Cmds:	Total R/W commands, all devices
R/W Bytes:	Total R/W bytes, all devices
Active Time:	Elapsed time of SCSI activity since first non-Bus Free SCSI Event
Active R/W Xfer Rate:	R/W Bytes / Active Time
Active R/Ws per Sec:	R/W Cmds / Active Time
R/W Time:	Elapsed Time of R/W Commands
R/W Xfer Rate:	R/W Bytes / R/W Time
R/Ws per Sec:	R/W Cmds / R/W Time
Avg R/W Xfer Size:	R/W Bytes / R/W Cmds
Bus Utilization:	Total Time On Bus / Active Time
R/W Data Phase(Bus%):	R/W Data Phase Time / Bus Time
Incomplete Cmds:	Number of Incomplete Commands
Min Bus Free Time:	Smallest Bus Free Time
Avg Bus Free Time:	Average Bus Free Time
Max Bus Free Time:	Maximum Bus Free Time

Table 2

Note: The totals for R/W Cmds and Bytes are based only on completed commands.

Active Time is computed from the first captured phase including Bus Reset but not including Bus Free to the last phase.

R/W Time is computed from the first phase of the first completed R/W command through the last phase of the last R/W command that was captured.

Total Bus Time is the Active Time minus the Bus Free times.

R/W Data Phase Time is sum of the time in R/W Data Phase regardless if the command completed.

Bus Free determination begins following the first non-Bus Free phase captured and continues to the last phase captured. If the last phase is Bus Free then it is not included in the calculation.

6.2.2.2 Stats for IDs by Nexus (iid,tid,lun)

# of Reads	Number of Reads
Bytes Read	Bytes Read
Read Time	Elapsed Read Time
Read Xfer Rate	Bytes Read / Read Time
# of Reads/Sec	# of Reads / Read Time
Rd DataIn(Bus%)	Rd Data In Phase Time / Bus Time
Disconnects/Read	Average # Disconnects per Read
# of Writes	Number of write commands
Bytes Written	Total Bytes Written
Write Time	Elapsed Write Time
Write Xfer Rate	Bytes Written / Write Time
# of Writes/Sec	# of Writes / Write Time
Wr DataOut(Bus%):	Wr Data Out Phase Time / Time On Bus
Disconnects / Write	Average # Disconnects per Write
R/W Xfer Rate	R/W Bytes / R/W Time
R/Ws per Sec	R/W Commands / R/W Time
% on Bus	Time on Bus / Elapsed Time
Incomplete Cmds	Number of Incomplete Commands

Table 3

Notes:

All calculations are based on R/W commands that have completed.

Read or Write Time is calculated from the ARB of the first completed Read/Write command captured through the Command Complete Message of the last Read/Write Command captured.

The **Bus Time** is the sum of all the connection time for the Nexus(iid, tid, lun) for commands that have completed.

The **% on Bus** calculation uses the connect time of completed commands for a Nexus and divides that by the Active Time for all devices described in the summary statistics.

6.2.2.3 R/W Size, Rates and Times for IDS

(Minimum, Average, Maximum Values by Nexus)

Read Size:	Byte Size for Read Commands
DataIn Size:	Byte Size for Read DataIn Phases
Rd Conn Rate:	Bytes Read / Read Time On Bus
Rd Brst Rate:	Bytes Read(DATA Phase) / DATA Phase Time
Rd Cmpl Time:	Initial ARB through the Command Complete Message for Reads
Write Size:	Byte Size for Write Commands
DataOut Size:	Byte Size for Write DataOut Phases
Wr Conn Rate:	Bytes Written / Write Time On Bus
Wr Brst Rate:	DATA Phase Bytes Written / DATA Phase Time
Wr Cmpl Time:	Initial ARB through the Command Complete Message for Writes
RW-RW Time:	For Non Tagged Queue Operations: Time from BUS FREE at end of command to ARB of next R/W command. For Tagged Queue Operations: Time from BUS FREE at end of command, (with Command Complete status), to the BUS FREE at the end of next R/W Command.
BusFree Time:	BUS FREE Time (This NEXUS by Itself)

Table 4

Notes:

All calculations are only based on R/W commands that have completed.

Read Time or Write Time on the Bus is the time from the initial ARB through the Command Complete Msg minus all the time between any disconnects and subsequent reconnects.

Bus Free time for a given Nexus is computed following the Command Complete or Disconnect Message until the ARB of a command with the same NEXUS, or until the ARB phase of a frame containing a Bus Device Reset Message for a Target in common with the given Nexus or until a Bus Reset is captured.

6.2.2.4 R/W Phase Time for IDS (min., avg., max.)

(Minimum, Average, Maximum Values by Nexus)

arb:	ARBITRATION Phase Time	(Starts on BUSY assertion)
arbwin:	ARBITRATION WIN Phase Time	(Starts on SELECT assertion)
reselect:	RESELECTION Phase Time	(Starts on SELECT assertion)
select:	SELECTION Phase Time	(Starts on BUSY de-assertion)
sel/rsel end:	SELECT/RESELECT END Phase Time	(Starts on SELECT de-assertion, BUSY active)
msgin:	MESSAGE IN Phase Time	(Starts at time-stamp for first message byte)
msgout:	MESSAGE OUT Phase Time	(Starts at time-stamp for first message byte)
command:	COMMAND Phase Time	(Starts at time-stamp for first command byte)
datain:	DATA IN Phase Time	(Starts at time-stamp for first data byte)
datain end:	DATA IN END Time	(Starts at time-stamp for last data byte transferred)
dataout:	DATA OUT Phase Time	(Starts at time-stamp for first data byte)
dataout end:	DATA OUT END Time	(Starts at time-stamp for last data byte transferred)
status:	STATUS Phase Time	(Starts at time-stamp for status byte)

Table 5

All phase times reflect time spent in a phase until start of the next phase. These phase times apply only to data R/W command related phases.

The SV-8160 and SV-3000 always capture in timing mode. As a result all phases are time-stamped as beginning at the initial transition defining those phases (REQ for most phases, BSY / SEL for ARB, SEL etc.)

For capture done on an SV-1620 or an SV-1600 the beginning of an **Data Out Phase** is as above except the start can be optionally, (user settable option), based on the assertion of REQ or the assertion of ACK. (See the **Options, Capture Options** dialog.)

For the informational input transfer phases (**MSGIN, STATUS, DATAIN, etc.**) the **phase will begin** with the correct setting of MSG and C/D, I/O high and REQ asserted.

Phase time percentages show each phase as a percentage of each device's active time (on bus time).

Datain phase time is the time in which data is actually being transferred, whereas **Datain End Time** is the time from last data phase byte transferred until the next phase begins. The same is true for **Dataout** and **Dataout End**.

For capture done on an SV-8020 the informational output transfer phases (**MSGOUT, CMD, DATAOUT**) the **phase will begin** with the correct setting of MSG and C/D, I/O low and ACK asserted.

6.2.2.5 Queue Tag Depth for IDS

Queue Tag Depth calculates tagged queue depth for R/W commands. (It does not include non-R/W commands that may be Queued.) Separate entries are shown for each initiator and target ID / LUN. Entries for initiators refer to the total R/W commands outstanding to all targets.

Avg	(Sum of all R/W Queue depths at Command Complete) / Total number of R/W commands
Max	Maximum number of Queued R/W commands at Command Complete
Min	Minimum number of Queued R/W commands at Command Complete
Current	Number of Queued R/W commands at the current sample point

Table 6

Current Performance View will update as activity occurs. For File-Performance runs the file is read in and will reflect the final depth at end of file. The end of analysis can be set using a Stop Marker for specific Queue depth points.

6.2.3 Filtering Performance Views by ID and LUN

File Performance Views can be restricted to display only selected SCSI IDs and LUNs. Clicking on the **Filter** button in the file selection dialog brings up the Filter dialog shown in Figure 51 below.

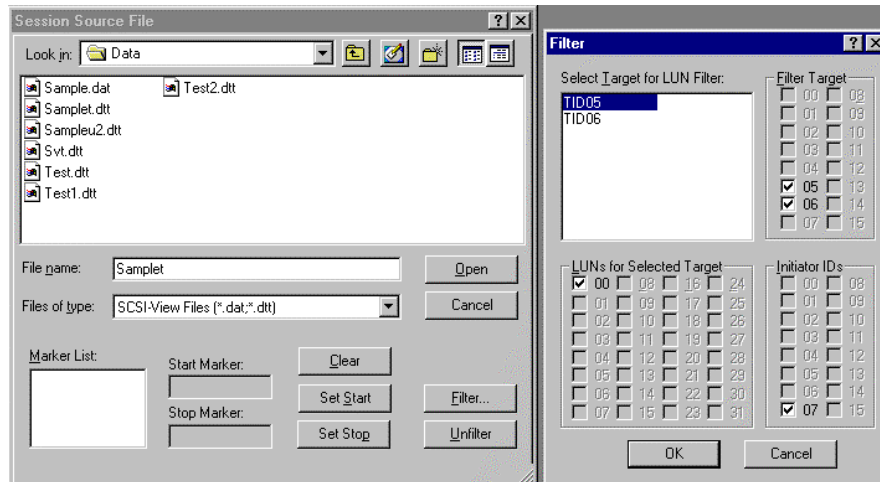

Figure 51

Only IDs and LUNs that were present in the session will be shown. Clicking on the bracket area next to each ID and LUN toggles its enable on and off. (X signifies that that IS or LUN will be displayed.)

Multiple File Performance Views can even be opened at the same time with different filters to View a session from different perspectives.

Note: Only **File** Phase, Command and Performance Views can be filtered by ID and LUN. **Current** Phase, Command and Performance Views can only be Viewed in the unfiltered mode.

6.3 Timing Waveform Analysis

Timing capture files can be viewed as a Timing View, Phase View, Command View or Performance View. (SCSI-View software automatically builds the higher level Views from the low level timing information.) SCSI-View Command, Phase and Timing Views can all be linked to correlate events in these different hierarchical Views. Timing capture files can be searched for low level signal sequences in Timing View, or they can be searched via higher level SCSI events when linked to a Phase View.

The RAM Buffer for Capture option allows direct capture to PC RAM without spooling to Disk. This significantly increases the maximum SCSI-View capture rate for very active SCSI systems.

The SV-8160 / SV-3000 always capture in the Timing mode. Phase, Command and Performance Views are built up from basic timing capture files by the SCSI-View software.

For the SV-1620 and SV-1600 Verisys recommends that Timing View users run SCSI-View on PCs with at least 16 MB of system memory for best performance.

6.3.1 Normal and Recirculate Capture (SV-8160 / SV-3000)

The SV-8160 (8 million events) and the SV-3000 (two million events) feature large buffers in the analyzer Pod. These buffers can be used either as a large FIFO buffer which is continually unloaded by the host computer (Normal Capture), or as a stand alone circular buffer (Recirculate Capture). Normal Capture can generate very large data files (up to 42GB per file) of SCSI activity, but at a lower system throughput due to disk write and PCMCIA throughput limits. Recirculate capture has the advantage that it can capture 100 percent of SCSI activity, including data phases to the extensive RAM buffer. A recirculate capture session can be stopped either by satisfying trigger conditions or by user intervention.

Different Capture Options and Trigger dialogs are displayed for Normal and Recirculate capture.

The SV-8160 and SV-3000 can be switched between capture types by pressing the <ALT-R> key, or by clicking on the “**CHG TYPE**” button on the toolbar. SCSI-View will indicate the current type of capture on the status line at the bottom of the screen.

6.3.2 Enabling Timing Capture Mode (SV-1620 / SV-1600)

On the SV-1620 and SV-1600, with the Timing Option installed, users may switch between Timing capture and SCSI Phase capture modes. Phase capture mode is more efficient in its use of capture file resources due to its hardware SCSI phase recognition engine. Timing mode provides the highest level of capture detail at the expense of larger system throughput and file sizes (approximately 5 to 10 times that of Phase capture.)

To toggle between Phase and Timing capture modes on the SV-1620 / SV-1600, select **Options, Phase / Timing Capture Mode**, or type **Alt-m**. SCSI-View will indicate the current mode of capture on the status line at the bottom of the screen. When Timing capture is selected by the user, a timing capture engine is downloaded to the FPGA_capture hardware in the SCSI-View POD. When Phase capture is selected, the Phase recognition and capture engine is downloaded to the FPGA hardware.

Timing mode capture files use the suffix .DTT. Phase mode capture files (SV-1620, SV-1600, SV-8020 only) use the suffix .DAT.

6.3.3 Capture Options for Timing

The **Options, Capture Options** dialog has several features that relate to Timing capture. (For a complete description of Capture Options see section 7.3.13 on page 158.)

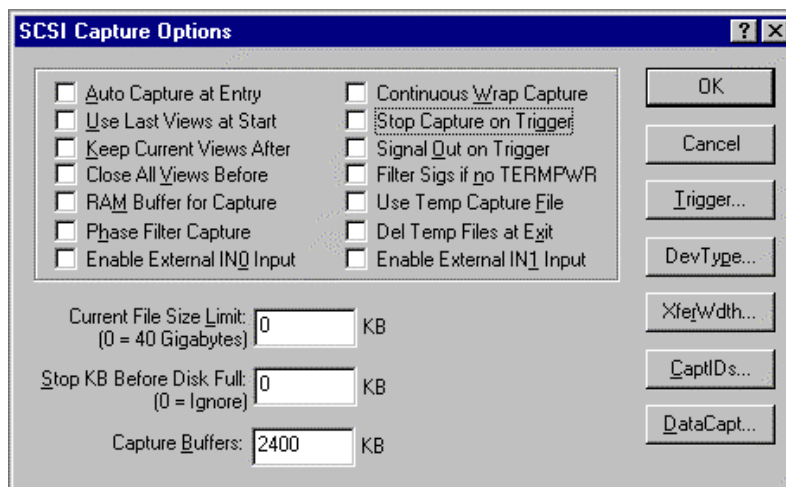

Figure 52 (SV-8160 / SV-3000 Capture Options, Normal Capture Mode)

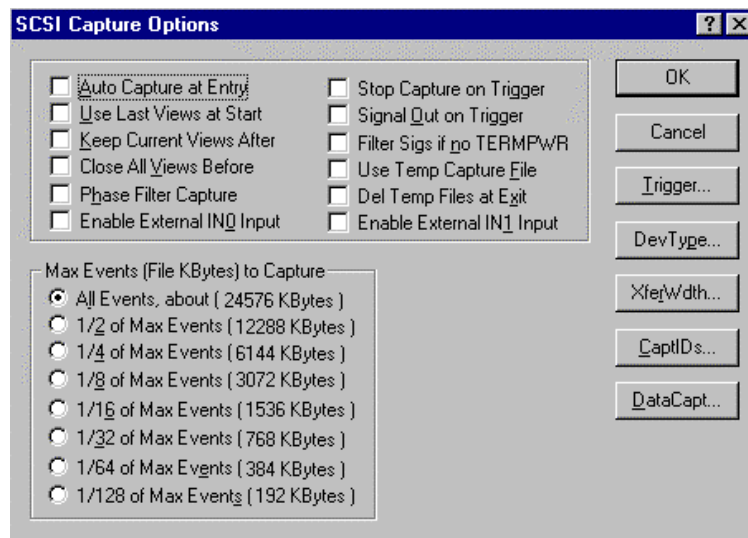

Figure 53 (SV-8160 / SV-3000 Capture Options, Re-circulate Capture Mode)

6.3.3.1 RAM Buffer for Capture (Normal Mode)

The **RAM Buffer for Capture** option enables direct capture to PC RAM without automatic spooling to disk. After a capture is ended, this buffer is automatically transferred to a disk file. This eliminates any storage latency due to hard disk accesses which significantly increases maximum analyzer capture rates. (This option can also be used for Phase capture.) When this option is chosen a file size limit of up to 20MB (20000k) must also be set. (PCs with less than 16Mb of DRAM will have smaller maximum RAM buffer limits.) **Continuous Wrap Capture is typically chosen** with RAM Buffer Capture to provide for buffer wrap around while waiting for a trigger or for the user to manually end the capture.

16MB of system memory must be installed on the SCSI-View host PC to take maximum advantage of RAM Buffer for Capture. (32 MB recommended.)

6.3.3.2 Capture All Data

The **DataCapt** sub dialog includes a **Capture All** Data option which is available for both Timing and Phase mode capture. When capturing in Normal mode on the SV-8160, the SV-3000, or any capture mode on the SV-1620 / SV-1600, this option should be used with caution, especially in timing mode, due to the very large amount of capture information it will create. If the SCSI-View front end appears to slow down appreciably (due to excessive capture flow), you can press the **CTRL-Break** keys to stop capture.

The SV-8160 and SV-3000, when running in Re-circulate mode to its on board Pod RAM buffer, are not bandwidth limited for Data Capture All.

6.3.3.3 Triggers

Trigger options for Normal Timing Capture mode (SV-8160 / SV-3000) are the similar to those available for Phase capture on the SV-1620, SV-1600. The Trigger options for re-circulate Capture mode (SV-8160 / SV-3000) are unique to that mode. See the Trigger section in Chapter 7 for a complete description of each trigger option.

6.3.4 Timing View

The Timing View can be opened as either as a **Current Timing** View during capture or as a File Timing View after capture is halted. Both Views are available from the **Analysis** pull down menu.

The Timing View, Figure 54, displays each SCSI signal line in a number of user selected formats. SCSI Data can be displayed in Hex, Binary or Waveform formats. Waveforms can be displayed as Active High or Active Low with the active level denoted by a double line. See the **Popup Options (F2 or Right Mouse Button)**, for timing to change these options.

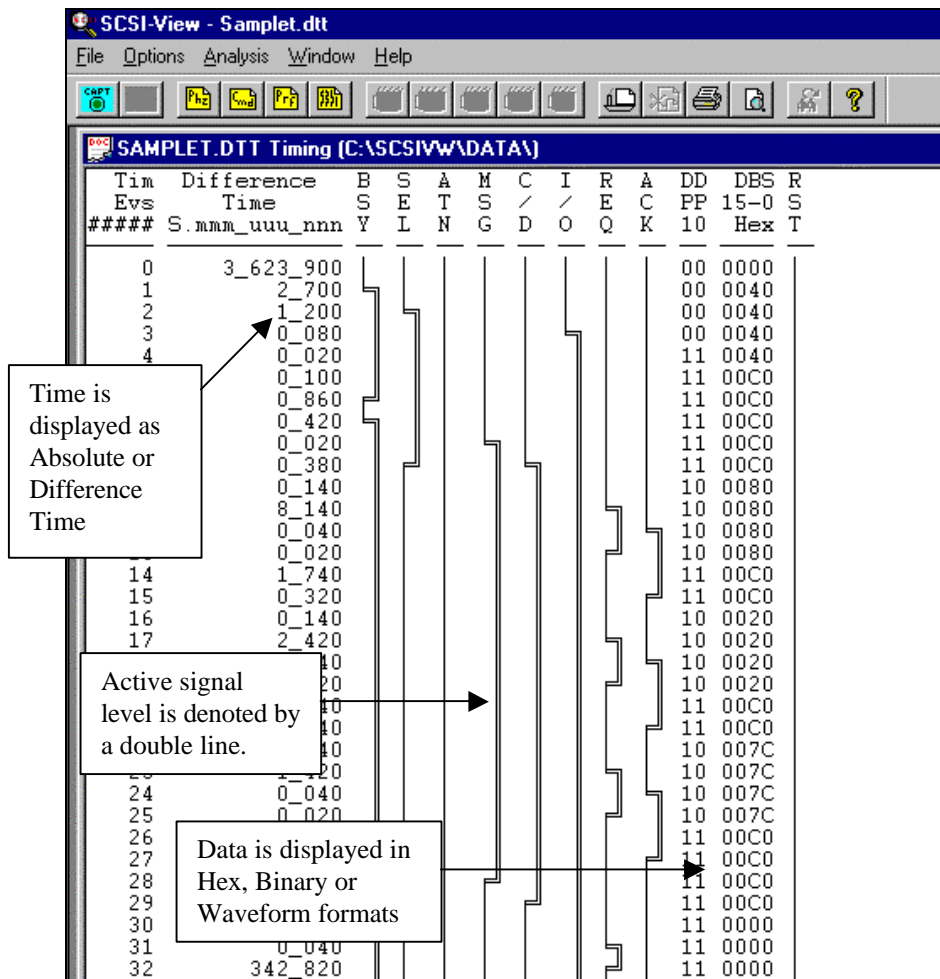

Figure 54

6.3.5 Timing Popup Operations

The Timing Popup window can be activated by clicking the Right Mouse Button, or by pressing F2 while viewing a Timing View. (These options can also be initialized via the **Options, Popup Display Defaults** menu item.

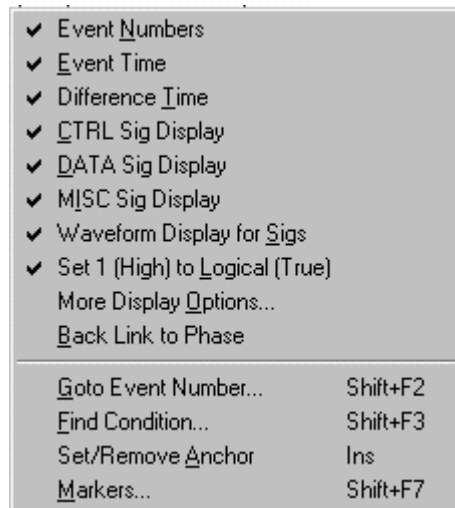

Figure 55

6.3.5.1 Show / Remove Event Numbers

Toggles on / off the display of signal transition event numbers.

6.3.5.2 Show / Remove Event Time

Toggles on / off the display of signal event time stamps.

6.3.5.3 Absolute / Difference Time

Toggles the time stamp between Absolute and Difference time stamps. Difference time is the time from the leading edge of one event to the leading edge of the following event.

6.3.5.4 Remove / Display CTRL, DATA and MISC Signals

Toggles on / off the display of CTRL, DATA and MISC signal groups.

6.3.5.5 Bit 1/0 - Waveform Display

Toggles between 1/0 display, and waveform display of signals.

6.3.5.6 Set 1 (high) to Logical True / False

Toggles the Waveform and I/O displays between active high (1 = Logical True) and active low (0 = Logical True) displays. On the waveform display the active level is always shown with double lines regardless of the high / low active level. (See Figure 54)

6.3.5.7 More Display Options

This dialog is used for formatting timing displays. Individual signals can be added or deleted from the display. Signal display order can be changed. SCSI DATA PHASE data can be displayed as HEX, Binary or Waveform Signals and it can be displayed as 8 bit (Low Only) and 16 bit (Low & High) values.

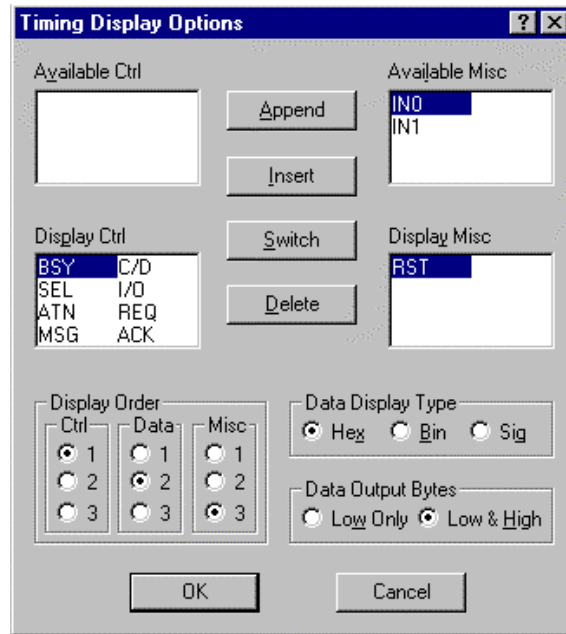

Figure 56

6.3.5.8 Enable Back Link to Phase

Toggles On/Off reverse linking to a host Phase View when the Timing View was created by double clicking on a Phase View line. Movement in the Timing View will be reflected in the Host Phase View when motion crosses SCSI phase boundaries.

6.3.5.9 Go To Event

Jumps to a user selected timing event number in the capture file.

6.3.5.10 Find Condition

Find Timing Condition searches for timing conditions at the signal level. (Instead of searching on SCSI events as is done in Phase and Command Views.)

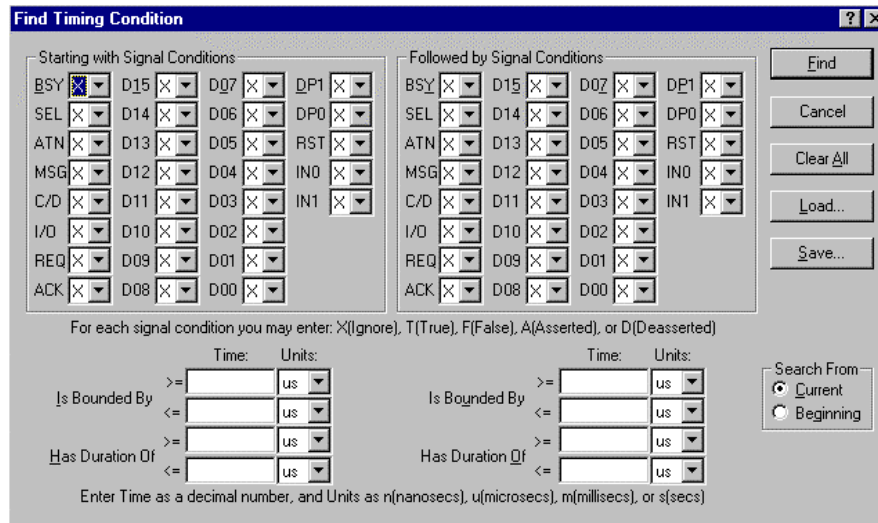

Figure 57

The **Starting with Signal Conditions** are applied to the signals of interest. If the first condition is to be constrained by time, then the time constraints are checked. Optionally the **Followed by Signal Conditions** can be set. If the starting conditions are met, then the followed by conditions must also be met to have a successful search.

The search may begin from the current event or from the beginning of the timing capture file. If a successful search occurs, then the highlighted bar will be positioned at the event that meets the search criteria

6.3.5.10.1 Timing Condition Search Algorithm

The timing search algorithm works as follows:

Starting from a given timing event (start of file or cursor position) **Starting Signal Conditions** need to be satisfied. If there is no match on these conditions, then failure is reported. If a match occurs on the conditions but the time constraints set are not satisfied then the search continues at the event following the first occurrence of these conditions. If there is a match and the time constraints are met and there are no **Following Conditions** set, then the search will stop successfully at the timing event of the first occurrence of the **Starting Signal Conditions**.

After the **Starting Conditions** criteria are met, the **Following Conditions** criteria are applied. If the **Following Conditions** group is met then the second pair of

time constraints are applied. If these time constraints are not met, then the search for the **Starting Conditions** will commence at the timing event after the occurrence of the **Following Conditions**. If the **Following Conditions** and associated time constraints are met, then the search will be successfully halted at the first occurrence of the **Following Conditions**.

For example, one might be interested in finding ACKs following Data In Phase whose times exceeded a set value. The starting signal conditions would be; BSY(T), SEL(F), MSG(F), C/D(F), I/O(T) and REQ(A). The bounded time might be $\geq 2m$, ensuring in most cases that we would get to the start of Data In. The Followed by condition would be; BSY(T), SEL(F), and ACK(A). If the bounded time were $\geq 5.28\mu$, then we would stop the search when we found the assertion of ACK occurring after the entry into Data In to exceed 5.28 microseconds.

6.3.5.10.2 Signal Condition Definition

A signal condition can be set on any of the 29 signals of the group. All the signal conditions set on the signals of a group must be met for the condition to be satisfied. The signal conditions are:

- **X** - Don't Care
- **T** - Logical True
- **F** - Logical False
- **A** - Assertion to True. The signal is in the logical True state and the previous timing event had this signal in the logical False state
- **D** - De-assertion to False. The signal is in the logical False state and the previous timing event had this signal in the logical True state.

At least one condition other than X must be set on a signal in the starting with signal group.

The signal conditions can be set by selecting the signal using a mouse (or tabbing to that signal) and entering the letters x, t, f, a, or d. These values can also be cycled by using the up and down arrows or the space bar.

6.3.5.10.3 Bounded Time / Duration Time Definition

The **bounded time** is the time from the start of search to the occurrence of the signal conditions set.

The **duration time** is the amount of time following the occurrence of the signal conditions that the conditions persist.

When a set of signal conditions have been met; e.g. REQ=T, ACK=A, then the duration of the condition is measured as the persistence of the set of conditions. If the condition of a signal was Assertion (A) or De-assertion (D), then the persistence of the signal would be remaining True(T) or False(F) respectively. If

the time of the persistence of the condition criteria fits within the duration time limits, then the duration time criterion has been satisfied. If not, then the search will proceed at the event following the persistence of the signal conditions.

The units of time to be entered are:

n - nanoseconds

- u - microseconds
- m - milliseconds
- s - seconds

The time unit can be set by entering the letters n, u, m, s. They can also be cycled by using the up and down arrows or the space bar.

6.3.5.10.4 Find Next

After a timing condition search is done and a match occurred, then **Alt-n, FindNext** will be activated (on the status line at the bottom of the screen.) The next search will proceed from the currently highlighted timing event.

6.3.5.10.5 Clear All

The **ClrAll** Button resets all signal conditions to their don't care (X) state and clears all time constraint fields.

6.3.5.10.6 Save

The Save Button brings up a dialog that allows the saving of the current search conditions to a user specified *.CND file.

6.3.5.10.7 Load

The Load Button brings up a dialog in which previously saved signal condition files can be loaded from a user specified *.CND file.

6.3.5.11 Extracting Smaller Files, Delta Time Measurement

Set / Remove Anchor (also activated by pressing the **Insert** key), toggles the current position_on / off as an anchor for time measurement and printing smaller file extractions. By setting an anchor at the current cursor point and then moving the cursor to another point in a Timing View the delta time between those two events is displayed in the lower left hand corner of the screen.

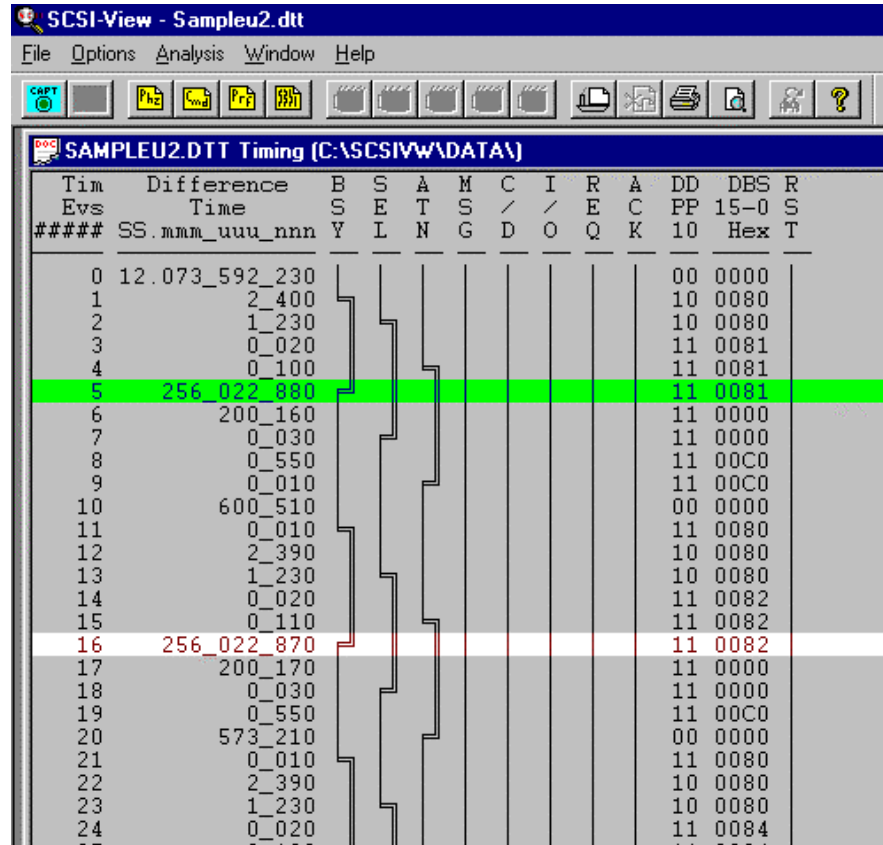

Figure 58

Use **File, Print** to print the current timing file from anchor to cursor.

6.3.5.12 Markers

The Markers dialog allows the creation of, and subsequent jumping to file markers at any timing event.

6.3.6 Linked Phase - Timing Views

Timing capture files (.DTT file suffix), can also be opened as Phase, Command and Performance Views in the **Analysis** menu. A Phase Views of Timing capture files can be linked to a Timing View in a similar manner to the way Command Views are linked to Phase Views.

To link a Phase View of a Timing mode capture file to a Timing View, double left click on a desired phase. (You can also press **F1** or use the Popup window to enable linking.) The linked Timing View will appear and follow the movement of the cursor in the Phase View.

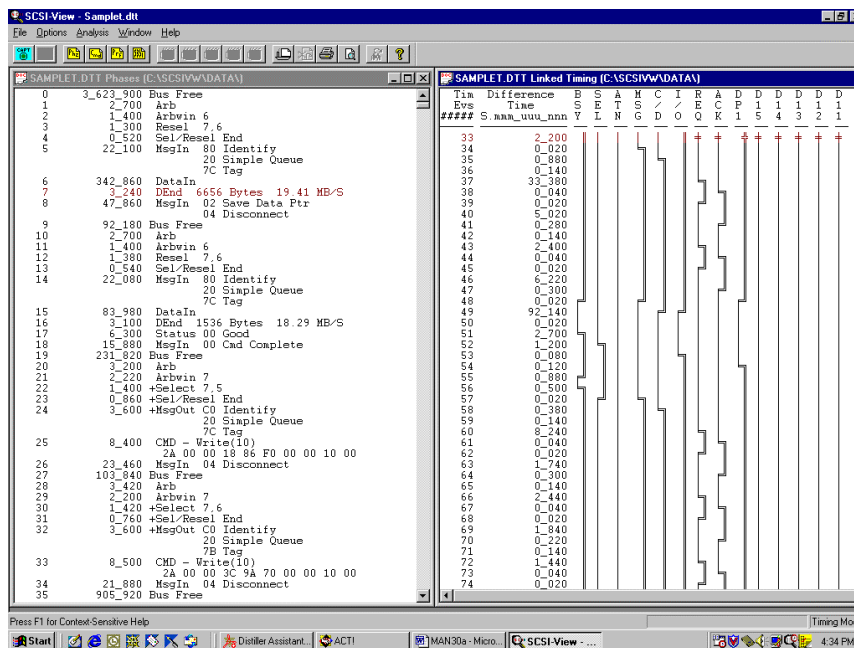

Figure 59

6.3.6.1 Linking to Specific Command, Message and Data Bytes

Individual bytes of multi-byte sequences in the linked Timing View can also be selected. Position the cursor on a desired Command, Message or Data phase line in the host Phase View. Pressing the **+** key will advance the Timing View cursor to the next byte in this sequence. Pressing the **-** key will move the Timing View backwards in the data sequence. Entering a number followed by the **+/-** keys will move the data by a relative offset. Entering a number followed by either **<** or **>** will move to an absolute byte offset.

Note: The lower right portion of the screen will display which linked data, command or message phase byte is currently highlighted (“Byte 4 of 512”). On output phases, this will initially display “byte -1 of xxx” since the cursor is

initially positioned at the first REQ of the output phase and the actual data is not transferred until the next ACK.

6.3.6.2 Enable Back Link to Phase (Popup Option)

Use this Popup window option to toggle On/Off reverse linking to a host Phase View from a linked Timing View. Movement in the Timing View will be reflected in the Host Phase View when motion crosses SCSI phase boundaries.

6.3.7 In Case of Problems

6.3.7.1 Timing mode requires the hardware to be enabled for timing.

This message indicates that your SV-1600 or SV-1620 hardware is not enabled for timing. This state is stored in an on board EEPROM. (The SV-8160 and SV-3000 are always enabled in timing mode.)

If you receive this message and you believe you have purchased the timing option for this specific analyzer, please contact Verisys customer support at: svsupport@verisys.com or **831-662-7900, 831-662-7910 FAX**. We will immediately mail or email you the files necessary to enable your hardware for timing. Please have your hardware serial number available, (from the **File, Hardware Information** dialog) when you contact Verisys.

6.3.7.2 Slow Current Window Updates, Buffer Overflow

On the SV-1620 / SV-1600 in timing mode, and the SV-8160 / SV-3000 in Normal Mode, timing mode capture generates five to ten times the activity as Phase mode capture. On the SV-8160 and SV-3000 you should switch modes to Re-circulate capture <ALT-R>. In normal mode on the SV-8160 and SV-3000 or in timing capture mode on the SV-1620 / SV-1600 you may need to reduce the size of Data phase capture and reduce the number of on screen active current Views during capture. In addition, use the **Capture to RAM Buffer** option in the **Options, Capture Options** screen to increase performance.

Your system may be running on less than 16 Mb of RAM in the host PC. Verisys recommends that users of the Timing Option upgrade their host PCs to 16-32 MB of DRAM if they are not already at that level.

6.4 Bus Inspector View

The SCSI Bus Inspector View, Figure 60, can only be activated during a current capture. (**Analysis, Curr Bus Inspector**) This View shows the status of each SCSI hardware line sampled every 300-500ms. Active lines are denoted with an **X**. This View is most useful for determining the status of a hung SCSI bus and stuck SCSI control lines and data bits. (On low to moderate activity busses, (low bus utilization.) the Bus Inspector may mostly display 'Bus Free.' This is due to the fact that low to moderate busses are most likely to be in the Bus Free state when the Bus Inspector samples the bus).

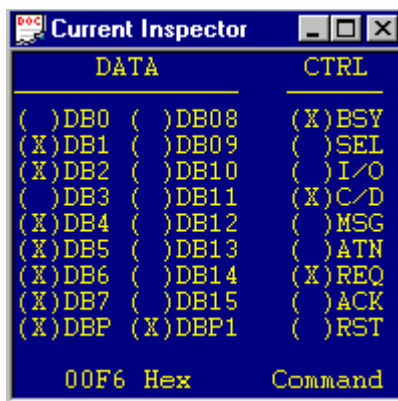

Figure 60

6.5 LED Indicators

The SV-8160 has two LEDs that display the analyzer's operational state. The LEDs are located on the side of the analyzer POD. The SCSI Status LED is at the SCSI connector end of the POD; the Analyzer Status LED is at the host connector end. The LEDs indicate the following information:

6.5.1 ANALYZER STATUS LED

Display	Message
LED Off	Analyzer has not been Programmed by Host
Steady Green	Analyzer Ready – Not Capturing
Blinking Green	Capturing in Normal Mode
Blinking Red	Capturing in Recirculate Mode
Steady Red	Recirculate Mode – Not Capturing

6.5.2 SCSI STATUS LED

Display	Message
LED Off	HVD Mode or Analyzer not Connected to Bus
Steady Green	LVD Mode – Termination Disabled
Blinking Green	LVD Mode – Termination Enabled
Steady Red	SE Mode – Termination Disabled
Blinking Red	SE Mode – Termination Enabled
Blinking Alternating Green and Red	Bus Hung – Not Bus Free and No Phase Changes for over 10 Seconds

7 Command and Menu Reference

In This Chapter:

7.1	The MAIN SCSI-View Screen.....	119
7.2	FILE	121
7.2.1	SCSI Capture Beg / End.....	121
7.2.2	Load Defaults.....	122
7.2.3	Save Defaults	122
7.2.4	Change Data Directory.....	122
7.2.5	Change Export/Print Directory.....	122
7.2.6	Change File Session Name.....	123
7.2.7	Delete Session File.....	123
7.2.8	Information.....	123
7.2.9	Hardware Information.....	124
7.2.10	Export.....	124
7.2.11	Extract.....	125
7.2.12	Print (Prints the active View).....	125
7.2.13	Exit.....	126
7.2.14	Unattended Capture with Pod Disconnected.....	126
7.3	OPTIONS	129
7.3.1	Hardware	129
7.3.2	Color Palette	130
7.3.3	Load Palette	130
7.3.4	Popup Operations.....	131
7.3.4.1	Phase View Popup Menu Operations.....	131
7.3.4.1.1	Show / Line Numbers	131
7.3.4.1.2	Show / Remove Phase Event Number.....	131
7.3.4.1.3	Show Event Time	131
7.3.4.1.4	Absolute / Difference Time	132
7.3.4.1.5	Show / Remove Extended Msg Display	132
7.3.4.1.6	Show /Remove Display of Data.....	132
7.3.4.1.7	Show / Remove ACSII Display	132
7.3.4.1.8	Back Link to Command.....	132
7.3.4.1.9	Go to Event Number	132
7.3.4.1.10	Find Operation.....	133
7.3.4.1.11	The Filter Button	134
7.3.4.1.12	Find Phase Time	135
7.3.4.1.13	Find Burst Rates	135
7.3.4.1.14	Extract Session File	136
7.3.4.1.15	Change Transfer Widths	136
7.3.4.1.16	Change Target Device Type.....	137
7.3.4.1.17	Set/Remove Anchor	137

7.3.4.1.18	Markers	138
7.3.4.1.19	Open Data Window.....	139
7.3.4.1.19.1	Data Window Popup Options.....	139
7.3.4.1.20	Link to Timing View.....	139
7.3.4.2	Command Popup Operations	140
7.3.4.2.1	Show / Remove Line Numbers	140
7.3.4.2.2	Show / Remove Event Numbers	140
7.3.4.2.3	Show / Remove Command Time	140
7.3.4.2.4	Time Display	140
7.3.4.2.5	Show SCSI CDB.....	141
7.3.4.2.6	Show / Remove Command Qualifier	141
7.3.4.2.7	Link to Phase View.....	141
7.3.4.2.8	Goto Command Number	142
7.3.4.2.9	Find Command	143
7.3.4.2.10	Find Completion Time	144
7.3.4.2.11	Change Transfer Widths	144
7.3.4.2.12	Change Device Type	145
7.3.4.2.13	Set/Remove Anchor	145
7.3.4.2.14	Markers	146
7.3.5	Timing Popup Operations.....	147
7.3.5.1	Show / Remove Event Numbers.....	148
7.3.5.2	Show / Remove Event Time.....	148
7.3.5.3	Absolute / Difference Time	148
7.3.5.4	Remove / Display CTRL, DATA and MISC Signals	148
7.3.5.5	Bit 1/0 - Waveform Display	148
7.3.5.6	Set 1 (high) to Logical True / False.....	149
7.3.5.7	More Display Options.....	149
7.3.5.8	Enable Back Link to Phase	149
7.3.5.9	Go To Event.....	149
7.3.5.10	Find Condition.....	150
7.3.5.10.1	Timing Condition Search Algorithm.....	150
7.3.5.10.2	Signal Condition Definition	151
7.3.5.10.3	Bounded Time / Duration Time Definition	151
7.3.5.10.4	Find Next.....	152
7.3.5.10.5	Clear All.....	152
7.3.5.10.6	Save	152
7.3.5.10.7	Load.....	152
7.3.5.11	Set / Remove Anchor	153
7.3.5.12	Markers	154
7.3.6	Display Views	154
7.3.7	Display Units.....	155
7.3.8	Modify Command Strings	155
7.3.9	Define Read/Write Opcodes.....	156
7.3.10	Timing Display Options	157
7.3.11	Popup Display Defaults	157

7.3.12	25/50 Lines	158
7.3.13	Capture Options	158
7.3.13.1	Auto Capture at Entry (to SCSI-View).....	159
7.3.13.2	Signal Out on Trigger (SV-8160 / SV-3000).....	159
7.3.13.3	Filter Sigs if no Power (SV-8160 / SV-3000 Re-circulate).....	159
7.3.13.4	Use Last Views at Start (of Capture)	159
7.3.13.5	Keep Current Views After (End of Capture)	159
7.3.13.6	Close All Views Before (Starting Capture).....	159
7.3.13.7	RAM Buffer for Capture	160
7.3.13.8	Continuous Wrap Capture (Circular Buffer)	160
7.3.13.9	Stop Capture on Trigger	160
7.3.13.10	Use Temp Capture File (\$TEMP.DAT).....	160
7.3.13.11	Del Temp Files at Exit.....	160
7.3.13.12	Output-Phase Begins With: REQ/ACK.....	160
7.3.13.13	Current File Size limit	160
7.3.13.14	Stop KB Before Disk Full	160
7.3.13.15	Capture Buffers	161
7.3.13.16	Trigger	162
7.3.13.16.1	Normal Triggers (Also SV-1620 / SV-1600)	162
7.3.13.16.2	Re-circulate Triggers.....	164
7.3.13.17	Device Type.....	165
7.3.13.18	XferWdth	166
7.3.13.19	CaptIDs	167
7.3.13.20	DataCapt(ure Length).....	168
7.3.14	Normal / Recirculate Capt Type (SV-8160 / SV-3000)	169
7.3.15	Phase / Timing Capture Mode (SV-1620 / SV-1600).....	170
7.4	ANALYSIS	171
7.4.1	Phase and Command Views	172
7.4.1.1	Current Phases	172
7.4.1.2	Current Commands	172
7.4.1.3	File Phases	173
7.4.1.4	File Commands	174
7.4.2	Performance	175
7.4.2.1	Current Performance	175
7.4.2.2	File Performance	176
7.4.3	Bus Inspector	176
7.5	WINDOW	177
7.5.1	Next.....	177
7.5.2	Zoom	177
7.5.3	Close.....	177
7.5.4	Close All.....	177
7.5.5	Size.....	177
7.5.6	Move.....	178
7.5.7	Cascade.....	178

7.5.8	Tile	178
7.6	HELP	179
7.6.1	Index.....	179
7.6.2	Getting Started	179
7.6.3	Cursor Movement Keys	180
7.6.3.1	SCSI-View Cursor Movement Key Descriptions	180
7.6.4	Function & Hot Keys.....	180
7.6.4.1	SCSI-View Function and Hot Key Descriptions	180
7.6.5	Mouse Functions	182
7.6.5.1	SCSI-View Mouse Functions	182
7.6.6	Technical Support	183
7.6.7	About	183

7.1 The MAIN SCSI-View Screen

The SCSI-View Main screen contains the top Menu Bar, the Toolbar, the Desktop Area and the bottom Status line.

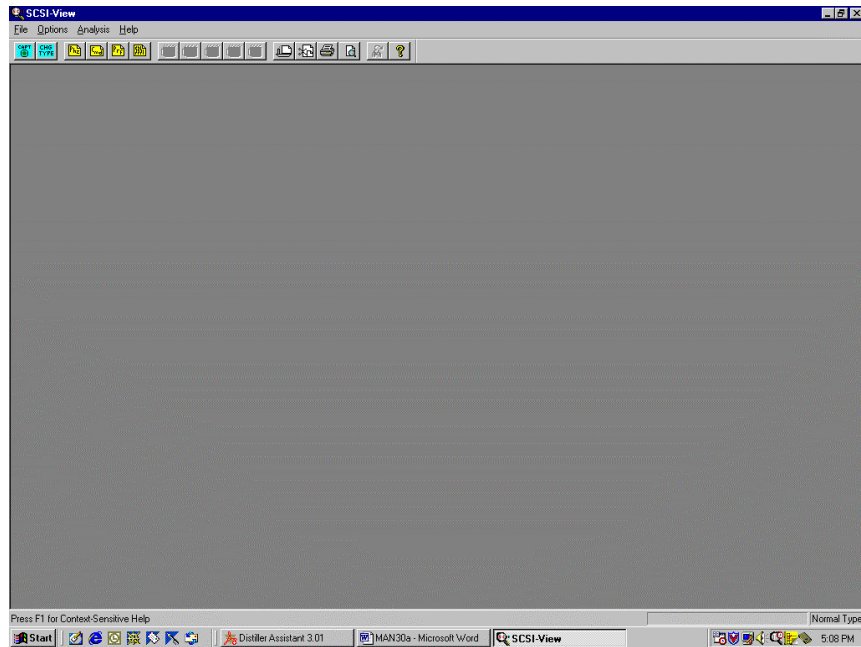

Figure 61

The **top Menu Bar** contains the pull down menus for all of SCSI-View's commands. Clicking the mouse on any of these menu items will display a pull down list of commands. The user can either drag the cursor to a particular item and release it or just click directly on that item to select it. SCSI-View menus can also be navigated directly from the Keyboard. To select from the Menu, hold down the **<ALT>** key and type the highlighted letter of the desired category, (typically the first letter.) To select an item from a pull down menu, type the highlighted letter for that item. To the right of the menu titles is the capture status display. The SV-8160 and the SV-3000 display Normal or Re-circulate capture modes. The SV-1620 / SV-1600 display Phase and Timing capture modes.

The **Toolbar** below the Menu bar offers buttons for most of the common operations. The buttons from left to right are:

- Start/Stop Capture
- Change Capture Type
- File Phase View
- File Command View
- File Performance View
- File Timing View
- Current Phase View
- Current Command View
- Current Performance View
- Current Timing View
- Bus Inspector View
- Export Session View
- Extract Session View
- Printing
- Print Preview
- Find Next
- Context Help

The **Desktop Area** provides the backdrop for all of SCSI-View's display and analysis windows, including Protocol, Error, Performance and Tagged Queuing analysis windows. Any number of windows can be displayed and independently arranged on the screen.

The **Status Line** displays various system status messages from SCSI-View. It is divided into three areas:

- The current capture mode is displayed at the extreme right.
- During capture, a separate state pane displays capture status.
- All other status is displayed in the main status pane.

7.2 FILE

All File menu items operate on the currently focused window.

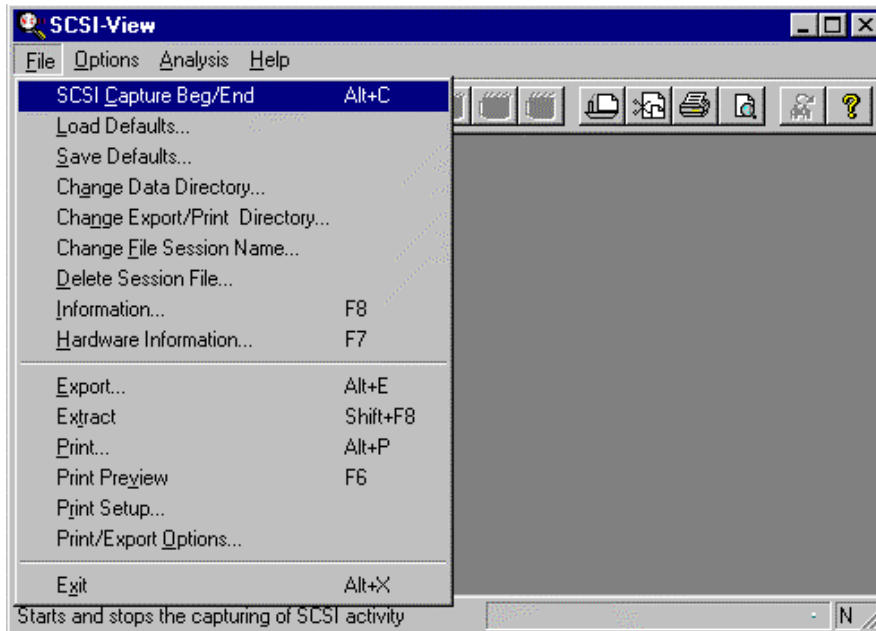

Figure 62

7.2.1 SCSI Capture Beg / End

Clicking on this item or pressing **ALT C** alternately starts and stops SCSI capture. (Current capture status is shown on the status line at the bottom of the SCSI-View display). Each time capture is started, SCSI-View will create a new capture file named **SVxx.DTT**, (xx is a serial number assigned sequentially), or a user defined name can be entered. A subsequent **Capture Beg** command will open a new capture file with the next available SVxx.DTT serial number. If the 'Use Temp Capture File' option is checked in **Options, Capture Options (F4)**, the file name \$TEMP.DTT will be used and overwritten for each capture.

For the SV-1620 / SV-1600, if the capture mode is set to phase (**Options, Phase/Timing Capt Mode**), each SCSI capture session will create a .DAT suffix for each file which denotes timing (waveform) mode capture, as opposed to timing mode (.DTT file), capture.

Stopping capture (**ALT C**) closes the current capture file.

7.2.2 Load Defaults

Loads previously saved user defined system default settings.

7.2.3 Save Defaults

Allows saving of most current system settings to a user named file. (**Note:** Timing search options are saved and retrieved in the Find Condition timing Popup dialog option.)

7.2.4 Change Data Directory

Change Data Directory selects different disk drives and directories for capture data storage and retrieval. The default data directory can also be set with a config.sys set directive: **SET SVDTTADIR = C:\anypath**. (*Replace 'anypath' with the actual path you wish to use on your system. This must be an existing directory.*)

Flushes current .DTT file information and writes it to the appropriate file. The file stays open during a current capture. This command is useful for insuring that all information captured up to a point in time is saved to a file, regardless of subsequent events such as power failures.

7.2.5 Change Export/Print Directory

This menu item invokes a file dialog that enables the user to switch the folder used for getting and saving of export/print files. To change the directory, one needs to alter the 'Look in:' field. If the 'Preserve as Default' checkbox is marked, then the newly selected export/print directory will persist following subsequent running of SCSI-View. Note however that if the SVPRINTDIR environment variable has been set then this will take precedence in establishing the export/print directory.

7.2.6 Change File Session Name

Change File Session Name allows changing of file names and entering of capture session descriptive information. (This information is also displayed when the File, Information command is used on a View.) This dialog is also useful for renaming the \$\$TEMP.DAT file when Use Temp Capture File is enabled in the Capture Options Dialog.

7.2.7 Delete Session File

This menu item selects the Delete Session File dialog. This dialog contains a list of *.DAT & *.DTT files in the current data directory. One of these files can be selected for deletion. If a session file is deleted, then the associated .IDX, .PFM, and .CPF files will also be deleted.

7.2.8 Information

The information box, Figure 63, displays general information about the current View file, trigger conditions met and SCSI-View Hardware / Software versions.

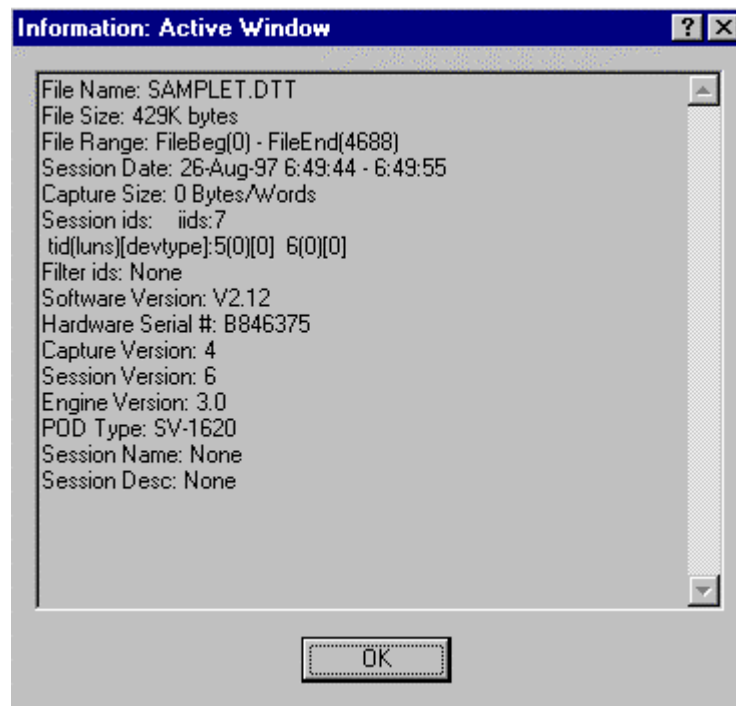

Figure 63

Targets active during the capture are displayed as 'tid(luns)[devtype]'. For target IDs with multiple LUNs having different device types, SCSI-View will show the last device type value returned during an inquiry for that target ID.

7.2.9 Hardware Information

Hardware Information displays information programmed into the SCSI-View Hardware at the factory and is not user modifiable. This information is used by Verisys customer service to determine customer hardware revisions and set-ups. It includes:

- Hardware ID and Serial Number
- Enable state of the Timing Option for each SV-1620 POD or SV-1600 card.
- Currently used I/O address and interrupt (DOS version only.)
- Amount of PC memory allocated for data buffering in SCSI-View

On the SV-8160, SV-3000, SV-1620 and SV-1600 analyzers, this window also displays the following SCSI BUS Status:

- Differential or Single Ended Interface (Differential Sense Line state)
- Term Power Detected or Not Detected by SCSI-View
- External Power to POD detected (SV-8160 / SV-3000 only).

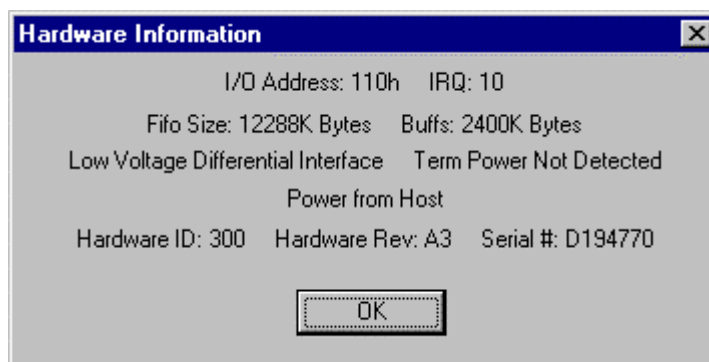

Figure 64

7.2.10 Export

This File Menu Item permits the selection of a file to which the focused window will be exported. Exporting of a view means translating the view proscribed by the range selected, into a .TXT file. The resultant file can be viewed with any text editor that can look at ASCII text. All views except Timing views have no headers or legends. The timing view will contain a legend identifying signal

names. Note also that a timing view containing signal waveforms will result in special U. S. codepage display characters being generated. A text file containing these special waveform characters can be viewed with Notepad if the Terminal font is selected.

The Export function will be active only if there is a focused analysis view. Export will not be selectable if the focused window is a data window, an inspector window or a linked SCAM waveform view. Export will also not be available for any Current views.

7.2.11 Extract

This Menu Item selects a dialog to create an extracted session file. Smaller print files can be extracted from a larger file through the use of the **Anchor and Regular cursors**. To mark the beginning (Anchor) of a print section place the cursor on the desired line in a Phase, Command or Timing View and press Insert. (The cursor will change color.) Then move the cursor to the end of the desired section and chose **File, Print**.

7.2.12 Print (Prints the active View)

This File Menu Item selects the standard Windows print dialog. It will be active only if there is a focused analysis view. Print will not be selectable if the focused window is a Data Window, and Inspector Window or a linked SCAM Waveform View. The Start and Stop Markers in effect for the View will also determine what range of the capture session is printed. (SCSI-View .DAT and .DTT capture files can be viewed as Timing, Phase, Command or Performance Views. See section 7.4, ANALYSIS, on page 171 for a complete description of each analysis View of a captured file.)

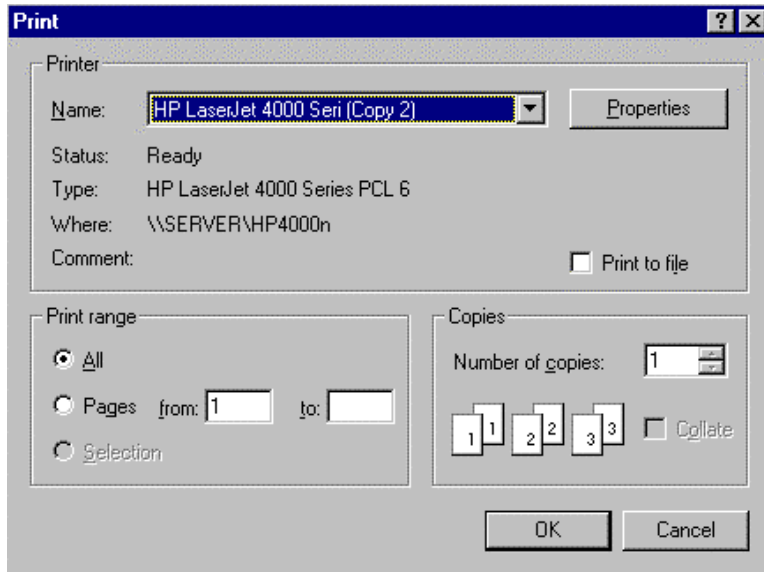

Figure 65

7.2.13 Exit

For the SV-1620 / SV-1600 and the SV-8160 / SV-3000 without external power to the POD, Exit (**Alt-X**) ends the current Session of SCSI-View. All open windows are saved and closed along with any associated files.

7.2.14 Unattended Capture with Pod Disconnected

The SV-8160 and SV-3000 Pods can continue SCSI capture while disconnected from its host laptop PC. Pods can be left on site for extended capture sessions.

To utilize this mode the following conditions must be met:

1. The SV-8160 / SV-3000 Pod must be powered from its external power adapter.
2. The analyzer must be in Re-circulate capture mode. (Capturing to the Pod hardware capture buffer.) Type **<ALT-R>** to change capture type.
3. Capture must be started with the notebook PC connected to the analyzer Pod. **<ALT-C>**

To initiate the disconnection sequence, start to exit the SCSI-View software by typing **<ALT-X>** or **File, Exit**. This will bring up the SV-Recirc Exit Confirmation dialog).

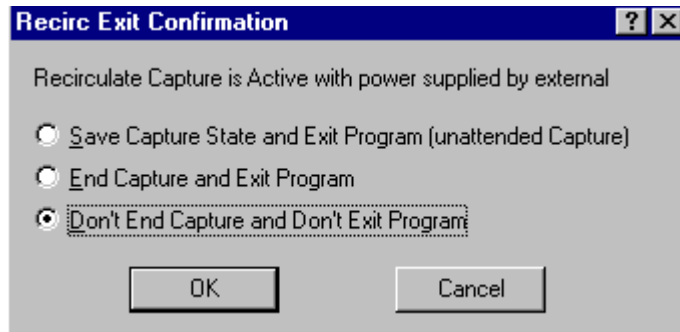
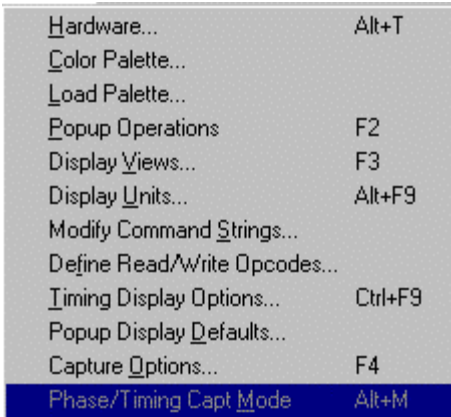

Figure 66

Choosing '**Save Capture State and Exit Program**' and clicking on **OK** will enable the POD for stand alone capture. Upon exit from the program the Pod may be disconnected from the host PC. (Make sure to keep the external power module connected to the POD.) Multiple PODs can be started capturing and then disconnected from the same host PC.

Reconnecting any active POD to the PC and starting SCSI-View will automatically cause SCSI-View to recognize the pod and to continue as if it had never been disconnected. If a hardware trigger event has occurred during capture, SCSI-View will end the capture, copy the event buffer to disk and display the capture status.

7.3 OPTIONS



H <u>ardware...</u>	Alt+T
C <u>olor Palette...</u>	
L <u>oad Palette...</u>	
P <u>opup Operations</u>	F2
D <u>isplay V</u> iews...	F3
D <u>isplay U</u> nits...	Alt+F9
M <u>odify Command S</u> trings...	
D <u>efine Read/Write O</u> pcodes...	
T <u>iming Display O</u> ptions...	Ctrl+F9
P <u>opup Display D</u> efaults...	
C <u>apture O</u> ptions...	F4
Phase/Timing Capt Mode	Alt+M

Figure 67

7.3.1 Hardware

(Termination, Differential / Single Ended Selection)

The Hardware Setup screen provides for enabling of SCSI termination, differential or single ended SCSI receivers and the control of the Interrupt and I/O locations used by SCSI-View.

Enable Low and Enable High enable the SCSI terminators in SCSI-View for the Lower Data bus and control lines and for the upper data bus (wide systems). When measuring narrow SCSI systems with the SV-1620 and SV-1600 make sure to check the Enable High termination box. This insures that SCSI-View will not see extraneous ID bits from a floating upper data bus.

The Enable Power box supplies to SCSI-Views terminators and differential receivers when there is no SCSI termination power present externally. Use the **File, Hardware Information** dialog to determine the status of termination power and single ended / differential bus type.

Automatic enables the SV-1600 / SV-1620 for either single Ended or Differential busses based upon the state of the diffsens line.

Single Ended and **Differential** manually enable either single Ended or Differential busses.

Test I/O checks the speed of the PCMCIA interface on the computer (Windows version of S/W only.)

Reset (SV-8160 / SV-3000 only) issues a hard reset to the SCSI bus.

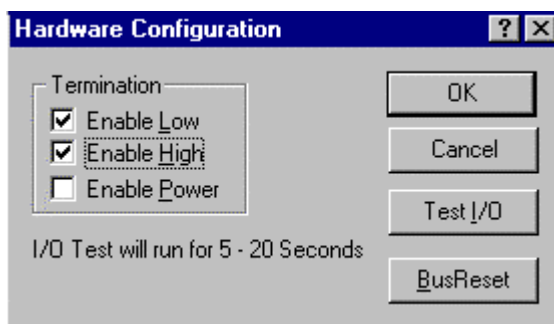

SV-8160 / SV-3000 Hardware Configuration Screen

Figure 68

7.3.2 Color Palette

This menu provides a Dialog for modifying SCSI-View's Color Palette.

7.3.3 Load Palette

Loads a user specified color palette definition. Two Palettes are provided with the product distribution. These are:

- COLOR.PAL - Default settings used for most VGA color displays.
- PLASMA.PAL - Used for orange plasma displays frequently used with portable 'lunchbox' computers.

7.3.4 Popup Operations

Popup Operations invokes the Popup Menu for the selected View. (Click on the desired Phase, Command or Performance View to select it, or press **F6** to toggle between selected Views.) It duplicates the action that pressing the right mouse key does in an active Phase or Command View. Figure 69 shows the Popup Menu for Phase Views, and Figure 80, page 140, shows the Popup window for Command Views.

7.3.4.1 Phase View Popup Menu Operations

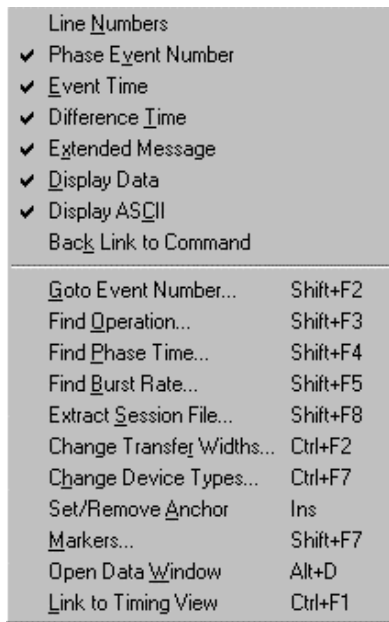

Figure 69, Phase View Popup Operations

7.3.4.1.1 Show / Line Numbers

Toggles the display of event/command line numbers in the current window.

7.3.4.1.2 Show / Remove Phase Event Number

Toggles the number display between phase event numbers and timing event numbers in Phase View.

7.3.4.1.3 Show Event Time

Allows the user to either show phase event time related to a displayed time, or to remove that displayed time.

7.3.4.1.4 Absolute / Difference Time

Toggles the Phase Event Time display between Absolute Time and Difference Time. Absolute time is calculated from the first SCSI phase of the capture session (usually Bus Free). Difference Time shows the actual time spent in each phase and is calculated from the beginning of the phase until the beginning of the following phase. (This is typically from the leading edge of the initial REQ of the first phase to the leading edge of the initial REQ of the following phase. ARB, ARB WIN, SELECT and SELECT WIN use the transitions of BSY and SELECT.)

7.3.4.1.5 Show / Remove Extended Msg Display

Toggles on/off the display of decoded extended messages (Synchronous, Wide-Narrow Negotiation, etc.).

7.3.4.1.6 Show /Remove Display of Data

Toggles on/off the display of captured data phase data.

7.3.4.1.7 Show / Remove ACSII Display

Toggles on/off the display of ASCII equivalents for data phase data. (Data phase data display must be enabled.)

7.3.4.1.8 Back Link to Command

Enables/disables back-linking from Phase to Command View. If back-linking is enabled, then when navigating through the focused Phase View, the Command corresponding to the highlighted timing event will be highlighted in the Command View.

7.3.4.1.9 Go to Event Number

Jumps to a user specified event number.

7.3.4.1.10 Find Operation

The **Find Operation** dialog provides a wide range of SCSI Commands, Conditions, Message Values and Status bytes that can be searched for. If a value is not present on either of the scrolling Condition or Command lists, Specific Message, Status, Command and Request Sense hex byte sequences can be entered directly.

See section 6.1.6 on page 82 for a detailed description of Phase and Command search options.

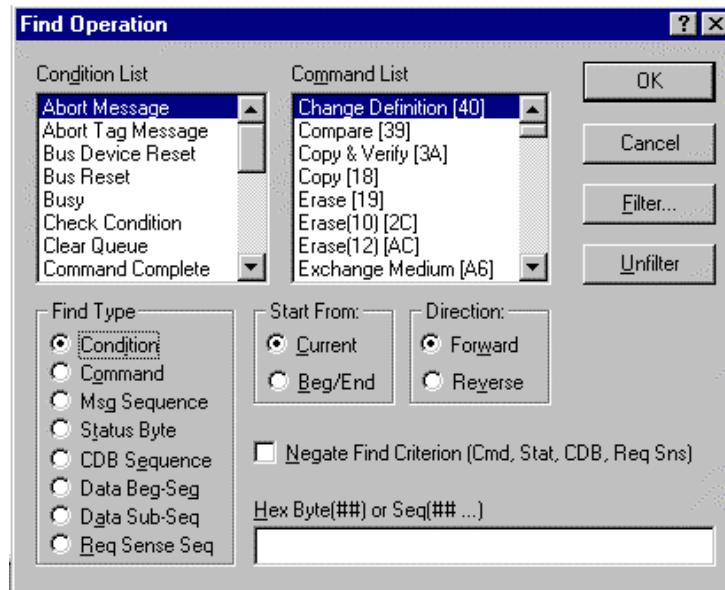

Figure 70

7.3.4.1.11 The Filter Button

Clicking on the Filter button brings up the Find, Filter Dialog, which allows selection of which IDs and LUNs will satisfy the search. Only those IDs and LUNs that were present in the capture session will be displayed.

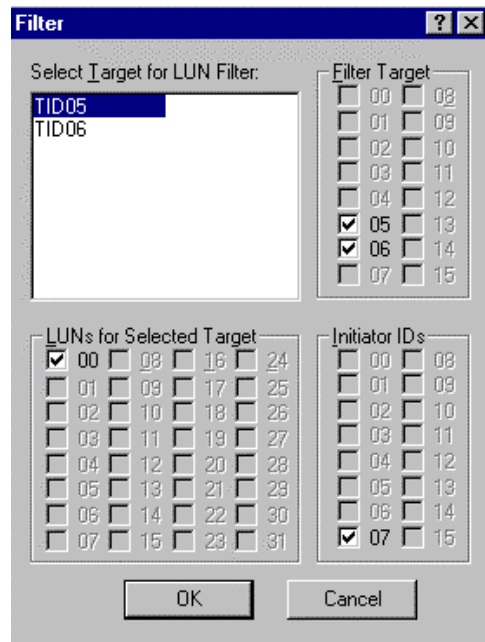

Figure 71

7.3.4.1.12 Find Phase Time

Find Phase Time searches for specific phases and phase duration times. The search can be started from the current location, or from the beginning of the file. This search can also be filtered by ID and LUN. Repeat the search by typing **<ALT> n** or clicking on **Search Next** on the bottom status line.

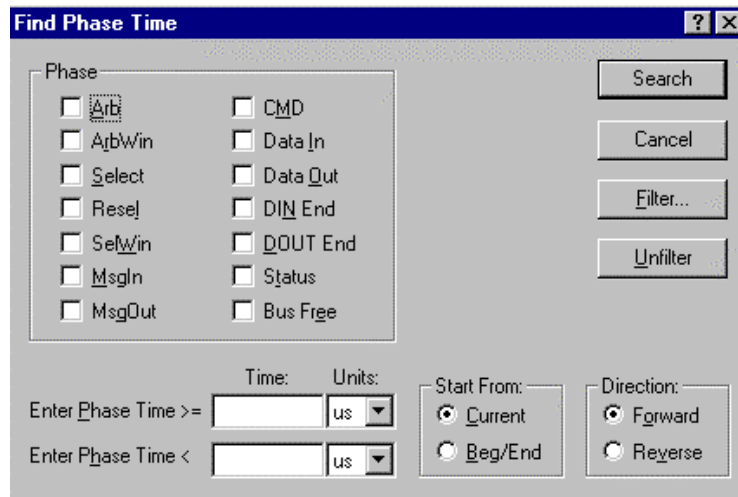

Figure 72

7.3.4.1.13 Find Burst Rates

Find Burst Data Rate searches for a specific range of Data Phase, R/W operation, data burst rates. The search can take place from the current location or from the beginning of the file. This search can be filtered by ID and LUN.

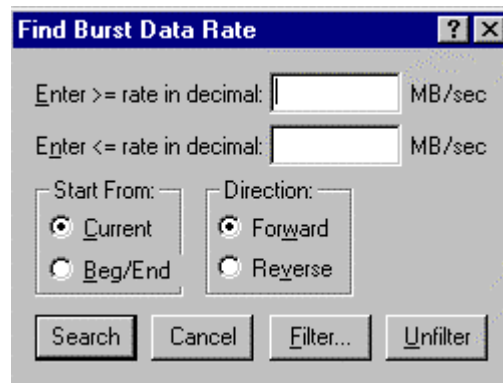

Figure 73

7.3.4.1.14 Extract Session File

Note: Extract can only be used while in the Phase View of a .DAT or .DTT file.

Extract Session File creates a smaller .DAT file from a larger Phase or Command View. Use the **Anchor and Current cursors to mark the range of operations to be extracted**. (Press **Insert** to set the anchor point to the current cursor location and then move the current cursor to the end of the desired selection. The resulting .DAT file can be viewed and analyzed by SCSI-View software.

7.3.4.1.15 Change Transfer Widths

This dialog resets the initial data width (wide or narrow) that SCSI-View will use to interpret data transfer operations for each target ID (**data counts, captured data display and calculated data rates**). This is a display option and can be changed at any time after a capture is complete. This option is useful when SCSI-View has been started after the initial target SCSI boot sequences that contain Wide-Narrow negotiations have completed. Any subsequent resets and Wide-Narrow negotiations present in a capture file will override this option.

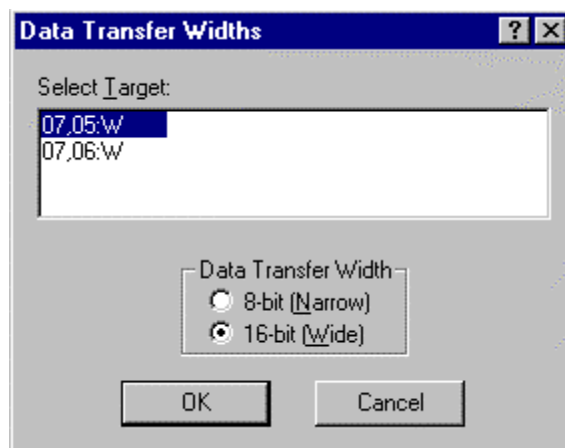

Figure 74

Above each ID nexus the phrases **OPN**, **SET** or **O&S** appear. **OPN** means that transfer width was never determined in the capture file and can be set by the user. **SET** means that the transfer width was set by negotiation or reset at the beginning of the capture file and can not be changed. **O&S** means that the transfer width was negotiated part way into the capture file. In this case the user can set the default width that will be used up to the point of first negotiation, reset, etc.

7.3.4.1.16 Change Target Device Type

Change Target Device Type changes the device type for any target ID and LUN. This change is permanently stored with the .DAT or .DTT file. SCSI-View uses device type to properly display the correct command strings in Phase and Command Views.



Figure 75

7.3.4.1.17 Set/Remove Anchor

Toggles the current cursor position in Phase or Command View to be an Anchor point for time measurements, printing and extraction. (This operation can also be performed by pressing the **Insert** key)

7.3.4.1.18 Markers

The Markers dialog, Figure 76, creates and edits location markers within the capture file. Any number of markers can be defined and changed during this dialog. Markers can be used to do the following:

- Jump to any defined marker using the Goto Event or Goto Command Popup operations.
- Set the limits for display in Command or Phase View when defined as start/stop markers in the file open dialog.
- Set the limits for analysis in Performance View when defined as start / stop points in the file open dialog.
- Set the limits for printing when defined as start / stop points in the file open dialog.

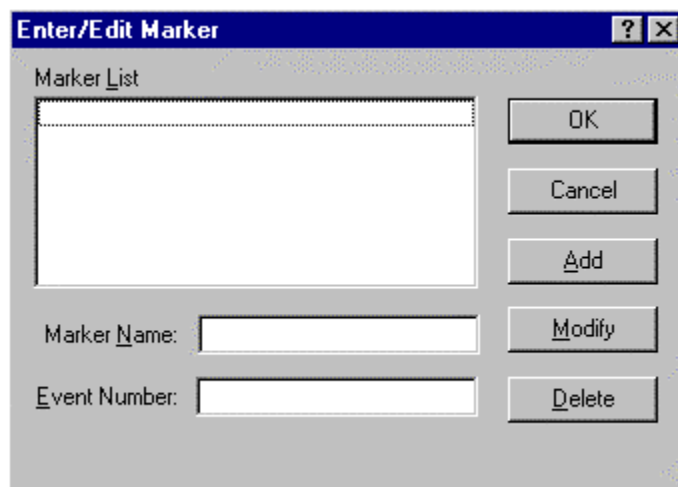

Figure 76

If a line in the Phase View is highlighted when this dialog is entered, the line number for that line will be entered as the event number.

When Start and Stop markers are used to define the limits of a Command View, the View will start with the first command whose initial ARB is later than or equal to the Start Marker, and will end with the last command whose initial ARB, and subsequent Bus Free are before or equal to the End Marker. (The end marker can be located on the subsequent Bus Free.)

7.3.4.1.19 Open Data Window

SCSI-View limits the data display in Phase Views to 32 bytes. This option allows the user to display the complete data phase capture in a separate window. The cursor must be positioned on a data phase for this option to be used. Up to two data windows per phase capture may be opened at once.

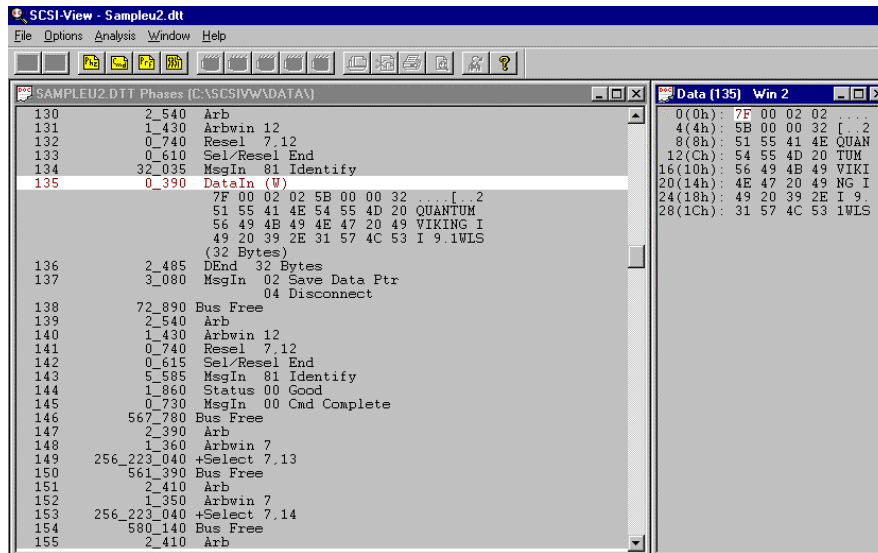

Figure 77

7.3.4.1.19.1 Data Window Popup Options

Pressing F2 or the right mouse button while in a Data Window brings up this Popup Menu. Options are provided to jump to any byte offset, find a byte pattern and to compare two data windows.

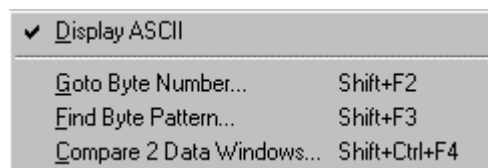

Figure 78

7.3.4.1.20 Link to Timing View

Creates a Timing View linked to the highlight position in the Phase View. Moving the highlight bar up or down in the Phase View will cause the movement of the corresponding highlight bar in the Timing View.

7.3.4.2 Command Popup Operations

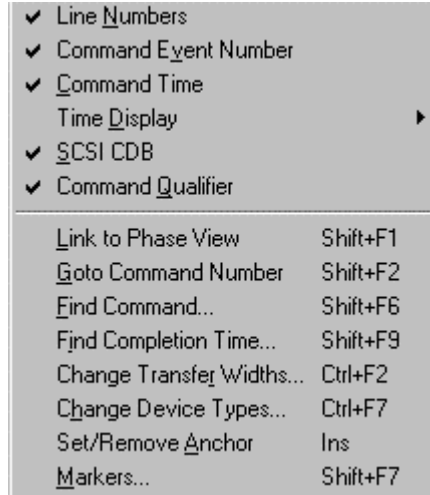

Figure 80

Command View Popup Menu

7.3.4.2.1 Show / Remove Line Numbers

Toggles the display of Command line numbers. (In contrast to Event numbers, which refer to individual phases, Command line numbers increment only for each new command block.)

7.3.4.2.2 Show / Remove Event Numbers

Toggles the display of the Phase event number corresponding to the first ARB for this Command block.

7.3.4.2.3 Show / Remove Command Time

Toggles the display of Absolute and Difference time.

7.3.4.2.4 Time Display

Toggles the Command Time display between Absolute Time, Command Completion Time, Difference and Active time.

- **Absolute Time** shows the current time stamp value
- **Command Completion Time** shows the actual time spent in each command and is calculated from the beginning of the ARB in the first command block until the beginning of the Bus Free following Command Complete for that command. In the case of commands with disconnects, this includes all the

time for intervening operations up until the final reconnect and Command Complete, followed by Bus Free.

- **Difference Time** shows the time from the initial arbitration of one command to the next commands initial arbitration.
- **Active Time** shows the actual time on bus for a command. This time does not include time used by intervening operations from other IDs.

7.3.4.2.5 Show SCSI CDB

Toggles on/off the display of CDB bytes on and off.

7.3.4.2.6 Show / Remove Command Qualifier

Toggles on/off the display of the number of disconnects, completion status and [TAG] value for each command.

7.3.4.2.7 Link to Phase View

Toggles creation of a linked Phase View centered on the current highlighted command. If no command was highlighted, the center command is chosen. Movement in the Command View causes a corresponding movement in the linked Phase View. For multi-disconnect commands the +/- keys will cause the linked Phase View to move through the multiple parts a highlighted command.

Linking can also be opened and closed by double left clicking on a command line.

7.3.4.2.8 Goto Command Number

Goto jumps to a specified Command line number, or to any of the user-defined markers shown in the list box.

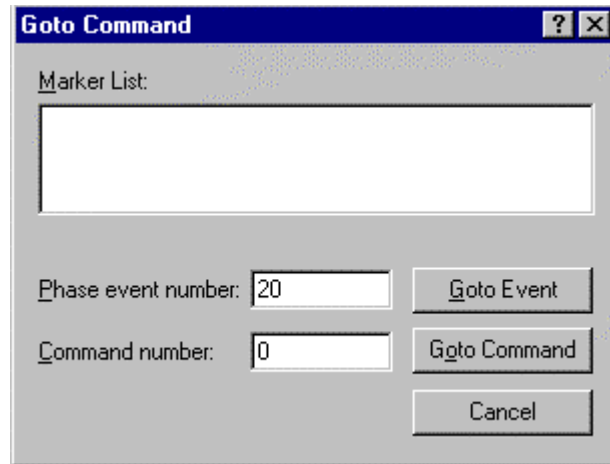

Figure 80

7.3.4.2.9 Find Command

Find Command searches for the next instance of the selected command. Select the desired command from the scrolling list box and check either **Current Position** or **Beginning of File** for the start of the search. Use the **Find Nth Command** Count box to find the Nth occurrence of a command. (Find command defaults to N=1.)

Find Command only searches in the forward (down) direction.

See section 6.1.6 on page 82 for a detailed description of Command search options.

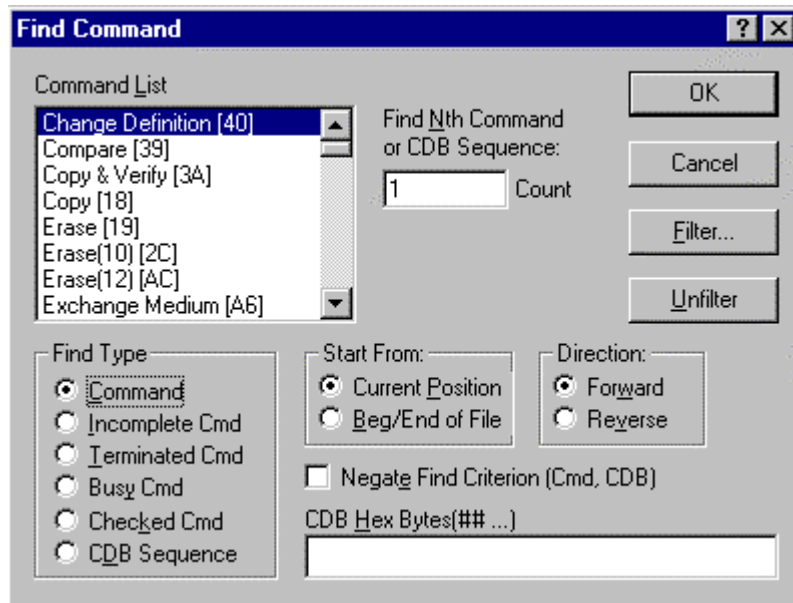

Figure 81

7.3.4.2.10 Find Completion Time

Searches for commands that are bounded by a range of command completion times.

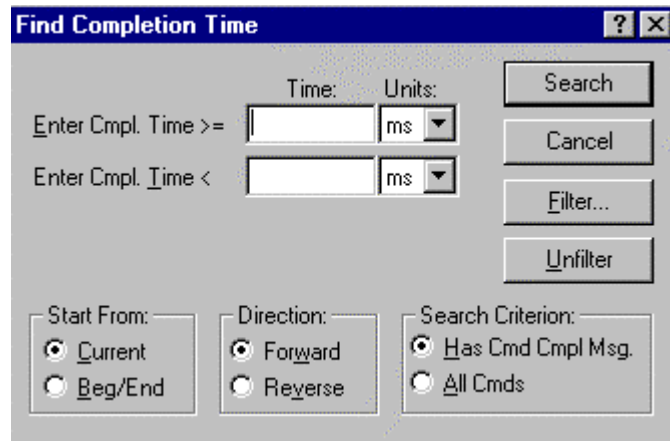

Figure 82

7.3.4.2.11 Change Transfer Widths

This dialog resets the initial data width (wide or narrow) that SCSI-View will use to interpret data transfer operations for each target ID (**data counts, captured data display and calculated data rates**). This is a display option and can be changed at any time after a capture is complete. This option is useful when SCSI-View has been started after the initial target SCSI boot sequences that contain Wide-Narrow negotiations have completed. Any subsequent resets and Wide-Narrow negotiations present in a capture file will override this option.

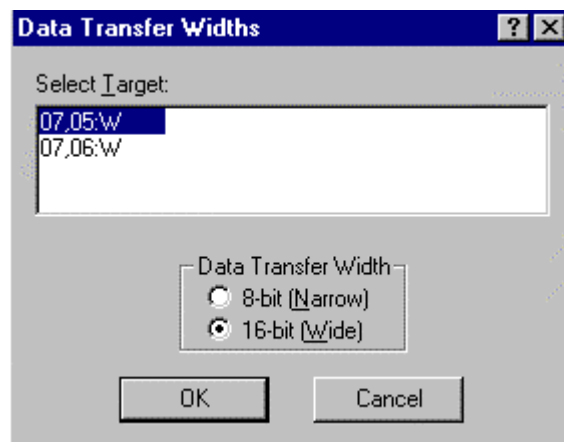

Figure 83

Above each ID nexus the phrases **OPN**, **SET** or **O&S** appear. **OPN** means that transfer width was never determined in the capture file and can be set by the user. **SET** means that the transfer width was set by negotiation or reset at the beginning of the capture file and can not be changed. **O&S** means that the transfer width was negotiated part way into the capture file. In this case the user can set the default width that will be used up to the point of first negotiation, reset, etc.

7.3.4.2.12 Change Device Type

Change Device Type changes the device type for any target ID. This change is permanently stored with the .DAT file. SCSI-View uses device type to properly display the correct command strings in Phase and Command Views.

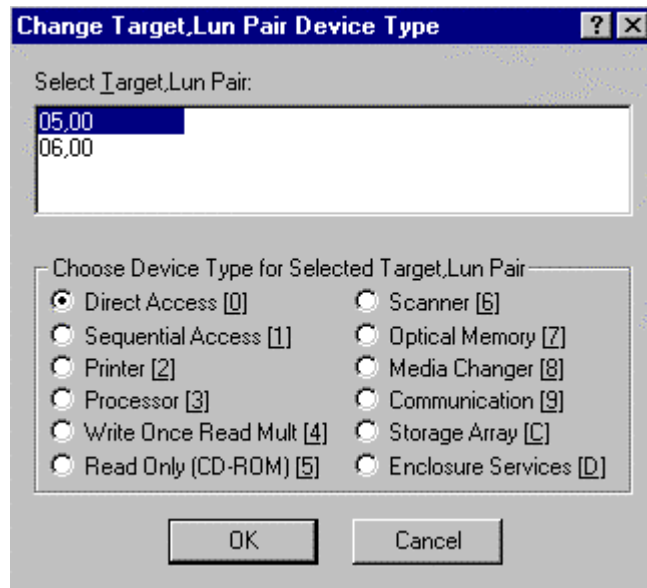

Figure 84

7.3.4.2.13 Set/Remove Anchor

Toggles the current cursor position in Phase or Command View to be an Anchor point for time measurements, printing and extraction. (This operation can also be performed by pressing the **Insert** key)

7.3.4.2.14 Markers

The Markers dialog, **Error! Reference source not found.**, creates and edits location markers within the capture file. Any number of markers can be defined and changed during this dialog. Markers can be used to do the following:

- Jump to any defined marker using the Goto Event or Goto Command Popup operations.
- Set the limits for display in Command or Phase View when defined as start/stop markers in the file open dialog.
- Set the limits for analysis in Performance View when defined as start / stop points in the file open dialog.
- Set the limits for printing when defined as start / stop points in the file open dialog.

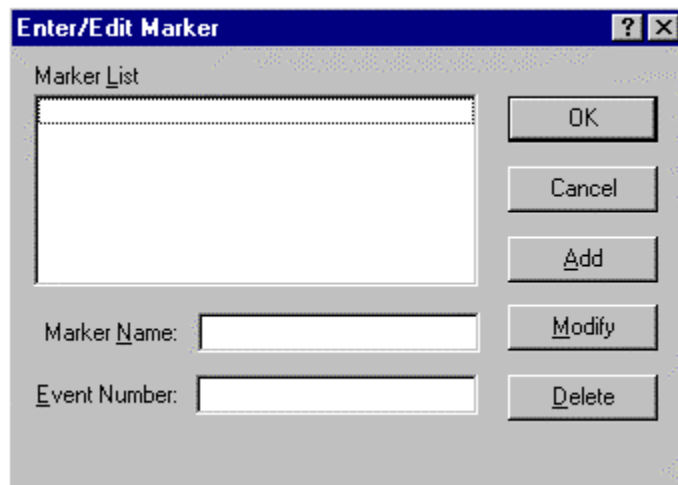

Figure 85

If a line in the Command View is highlighted when this dialog is entered, the line number for the first ARB of that Command will be entered as the event number.

7.3.5 Timing Popup Operations

The Timing Popup window can be activated by clicking the Right Mouse Button, or by pressing F2 while viewing a Timing View. (These options can also be initialized via the **Options, PopUp Display Defaults** menu item.

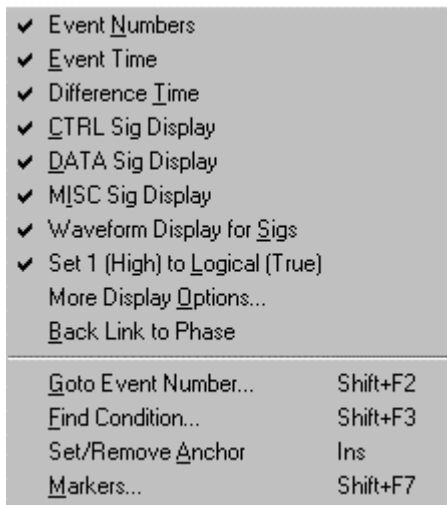

Figure 86

7.3.5.1 Show / Remove Event Numbers

Toggles on / off the display of signal transition event numbers.

7.3.5.2 Show / Remove Event Time

Toggles on / off the display of signal event time stamps.

7.3.5.3 Absolute / Difference Time

Toggles the time stamp between Absolute and Difference time stamps. Difference time is the time from the leading edge of one event to the leading edge of the following event.

7.3.5.4 Remove / Display CTRL, DATA and MISC Signals

Toggles on / off the display of CTRL, DATA and MISC signal groups.

7.3.5.5 Bit 1/0 - Waveform Display

Toggles between 1/0 display and waveform display of signals.

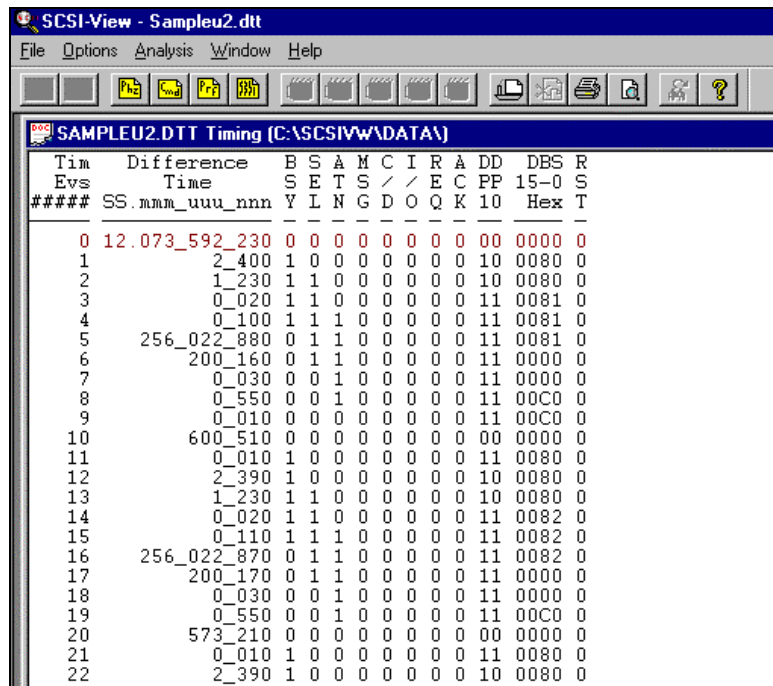

Figure 87

7.3.5.6 Set 1 (high) to Logical True / False

Toggles the Waveform and I/O displays between active high (1 = Logical True) and active low (0 = Logical True) displays. On the waveform display the active level is always shown with double lines regardless of the high / low active level. (See Figure 54)

7.3.5.7 More Display Options

This dialog allows Individual signals to be added / deleted from the display, signal display order to be changed, SCSI data to be displayed as HEX, Binary or Waveform Signals and SCSI data to be displayed as 8 bit (low Only) and 16 bit (low & high) values.

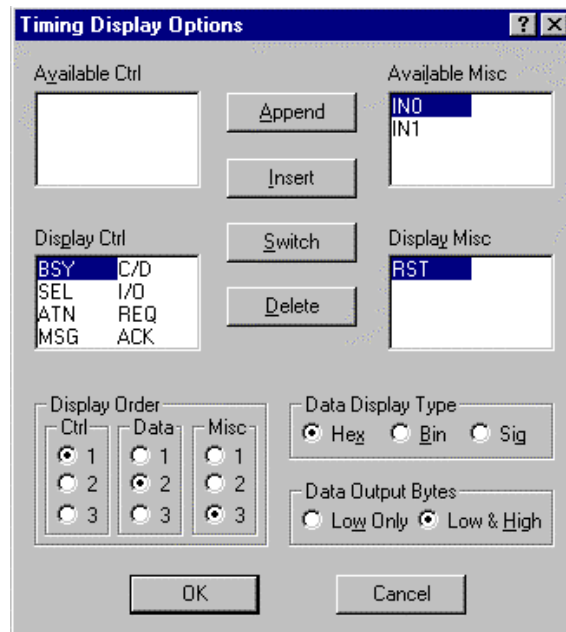

Figure 88

7.3.5.8 Enable Back Link to Phase

Toggles On/Off reverse linking to a host Phase View when the Timing View was created by double clicking on a Phase View line. Movement in the Timing View will be reflected in the Host Phase View when motion crosses SCSI phase boundaries.

7.3.5.9 Go To Event

Jumps to a user selected timing event number in the capture file.

7.3.5.10 Find Condition

Find Timing Condition searches for timing conditions at the signal level.

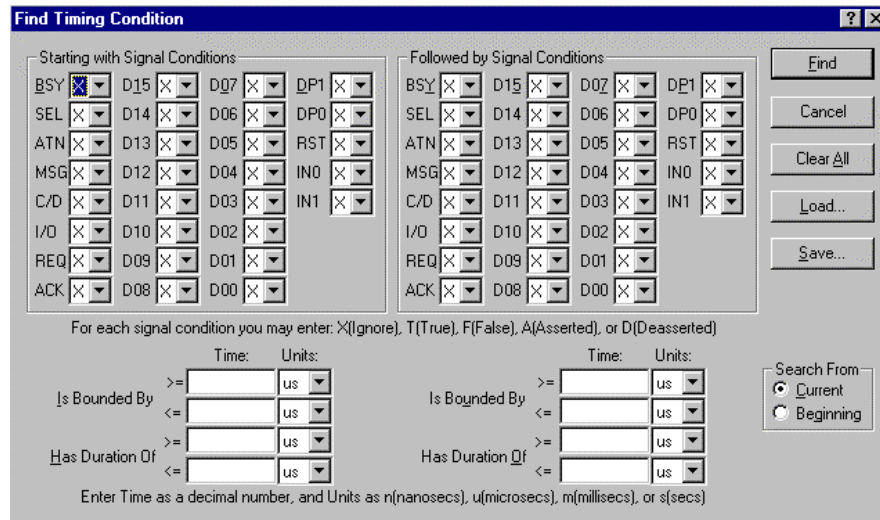

Figure 89

The **Starting with Signal Conditions** are applied to the signals of interest. If the first condition is to be constrained by time, then the time constraints are checked. Optionally the **Followed by Signal Conditions** can be set. If the starting conditions are met, then the followed by conditions must also be met to have a successful search.

The search may begin from the current event or from the beginning of the timing capture file. If a successful search occurs, then the highlighted bar will be positioned at the event that meets the search criteria

7.3.5.10.1 Timing Condition Search Algorithm

The timing search algorithm works as follows:

Starting from a given timing event (start of file or cursor position) the **Starting Signal Conditions** need to be satisfied. If there is no match on these conditions, then failure is reported. If a match occurs on the conditions but the time constraints set are not satisfied then the search continues at the event following the first occurrence of these conditions. If there is a match and the time constraints are met and there are no **Following Conditions** set, then the search will stop successfully at the timing event of the first occurrence of the **Starting Signal Conditions**.

After the **Starting Conditions** criteria are met, the **Following Conditions** criteria are applied. If **the Following Conditions** group is met then the second pair of time constraints are applied. If these time constraints are not met, then the search for the **Starting Conditions** will commence at the timing event after the occurrence of the **Following Conditions**. If the **Following Conditions** and associated time constraints are met, then the search will be successfully halted at the first occurrence of the **Following Conditions**.

For example, one might be interested in finding ACKs following Data In Phase whose times exceeded a set value. The starting signal conditions would be; BSY(T), SEL(F), MSG(F), C/D(F), I/O(T) and REQ(A). The bounded time might be $\geq 2m$, ensuring in most cases that we would get to the start of Data In. The Followed by condition would be; BSY(T), SEL(F), and ACK(A). If the bounded time were $\geq 5.28u$, then we would stop the search when we found the assertion of ACK occurring after the entry into Data In to exceed 5.28 microseconds.

7.3.5.10.2 Signal Condition Definition

A signal condition can be set on any of the 29 signals of the group. All the signal conditions set on the signals of a group must be met for the condition to be satisfied. The signal conditions are:

- **X** - Don't Care
- **T** - Logical True
- **F** - Logical False
- **A** - Assertion to True. The signal is in the logical True state and the previous timing event had this signal in the logical False state
- **D** - Deassertion to False. The signal is in the logical False state and the previous timing event had this signal in the logical True state.

At least one condition other than **X** must be set on a signal in the starting with signal group.

The signal conditions can be set by selecting the signal using a mouse (or tabbing to that signal) and entering the letters x, t, f, a, or d. They can also be cycled by using the up and down arrows or the space bar.

7.3.5.10.3 Bounded Time / Duration Time Definition

The **bounded time** is the time from the start of search to the occurrence of the signal conditions set. The **duration time** is the amount of time following the occurrence of the signal conditions that the conditions persist.

When a set of signal conditions have been met; e.g. REQ=T, ACK=A, then the duration of the condition is measured as the persistence of the set of conditions. If the condition of a signal was Assertion (A) or Deassertion (D), then the

persistence of the signal would be remaining True (T) or False (F) respectively. If the time of the persistence of the condition criteria fits within the duration time limits, then the duration time criterion has been satisfied. If not, then the search will proceed at the event following the persistence of the signal conditions.

The units of time to be entered are:

- n - nanoseconds
- u - microseconds
- m - milliseconds
- s - seconds

The time unit can be set by entering the letters n, u, m, s. They can also be cycled by using the up and down arrows or the space bar.

7.3.5.10.4 Find Next

After a timing condition search is done and a match occurred, then **Alt-n, FindNext** will be activated (on the status line at the bottom of the screen.) The next search will proceed from the currently highlighted timing event.

7.3.5.10.5 Clear All

The **ClrAll** Button resets all signal conditions to their Don't Care (X) state and clears all time constraint fields.

7.3.5.10.6 Save

The Save Button brings up a dialog that allows the saving of the current search conditions to a user specified *.CND file.

7.3.5.10.7 Load

The Load Button brings up a dialog in which previously saved signal condition files can be loaded from a user specified *.CND file.

7.3.5.11 Set / Remove Anchor

(Time Measurement and Extracting Print Files)

Set / Remove Anchor (also activated by pressing the **Insert** key), toggles the current position on / off as an anchor for time measurement and printing extraction. By setting an anchor at the current cursor point and then moving the cursor to another point in a Timing View the delta time between those two events is displayed in the lower right hand corner of the screen.

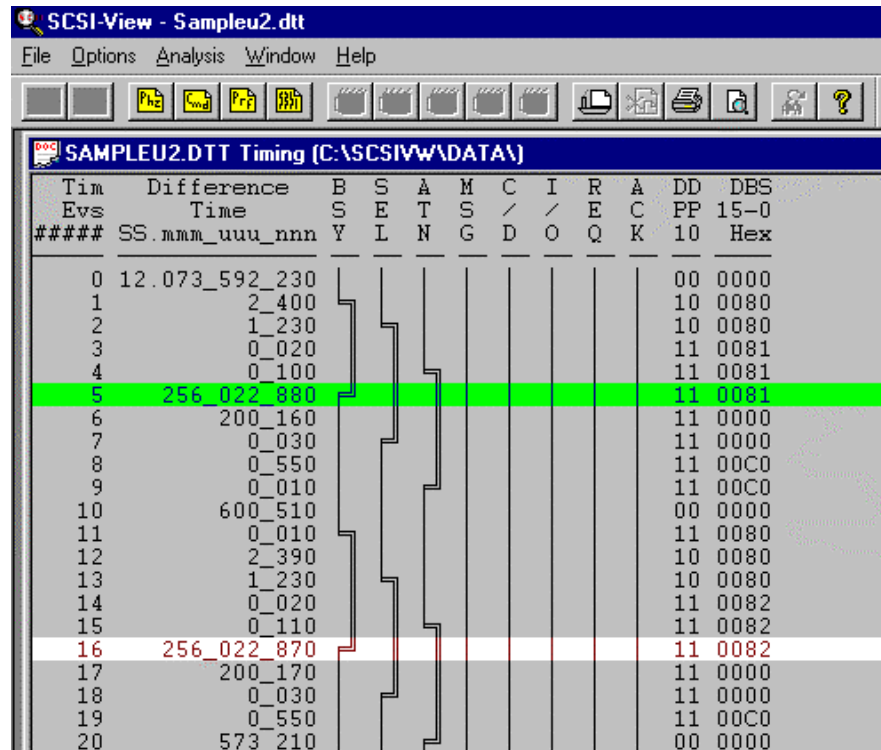

Figure 90

When **File, Print** is chosen, the current timing file can be printed from anchor to cursor.

To extract a smaller session file from a .DTT or .DAT file, the file must first be viewed with the Phase View. Then use the anchor and cursor to mark the extracted region.

See section 7.3.4.1.14 on page 136 for an explanation of extracting a smaller .DAT or .DTT session file from a larger one.

7.3.5.12 Markers

The Markers dialog allows the creation of, and subsequent jumping to, file markers at any timing event.

7.3.6 Display Views

The display views dialog defines the displayed text width and TAB movement values in each Analysis View. In addition, this dialog provides for the selection of which Performance View sections are displayed. Changes made in Display Views are reflected immediately in all displayed Phase, Command and Performance Views.

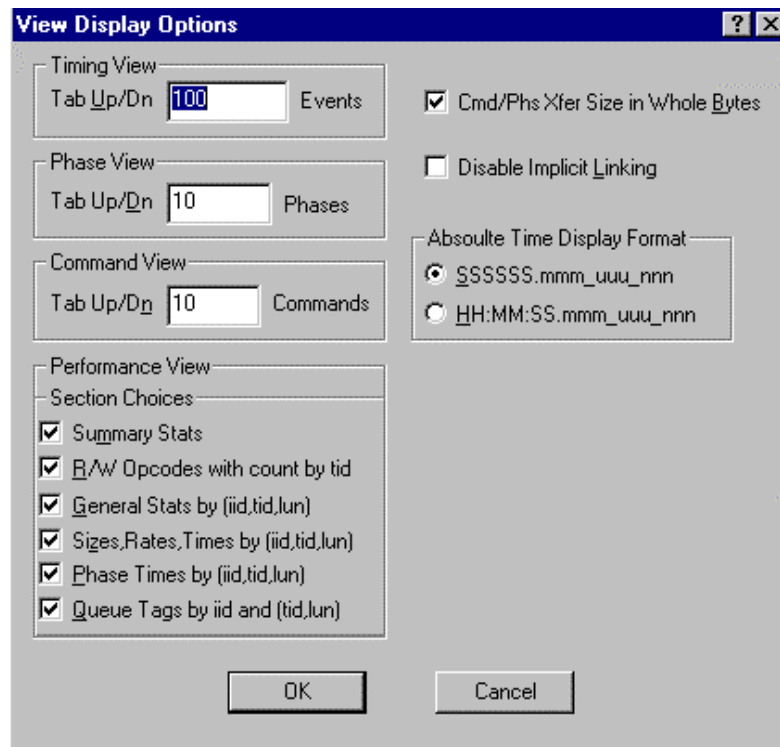

Figure 91

The Performance View option selects which Performance View sections to display.

CMD/PHS Xfer Size in Whole Bytes forces byte counts to be shown in exact amounts instead of rounded Kb, Mb values for large data transfers.

7.3.7 Display Units

The Display Units dialog sets the values used for the display of Kilobytes, Megabytes and Gigabytes. It also sets the units used for burst rate displays to Kilobytes or Megabytes. The default settings are shown below.

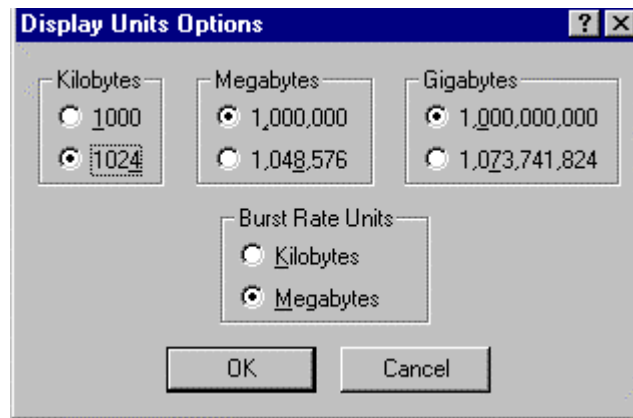

Figure 92

7.3.8 Modify Command Strings

The Modify Command Strings dialog allows user customization of the displayed command strings in Phase and Command. Separate command sets are defined for each of the standard SCSI device types.

To change a string value first select the desired Device Type and Command HEX Byte, and then edit the display string in the EDIT CMD STG box. Click on OK to save the edits.

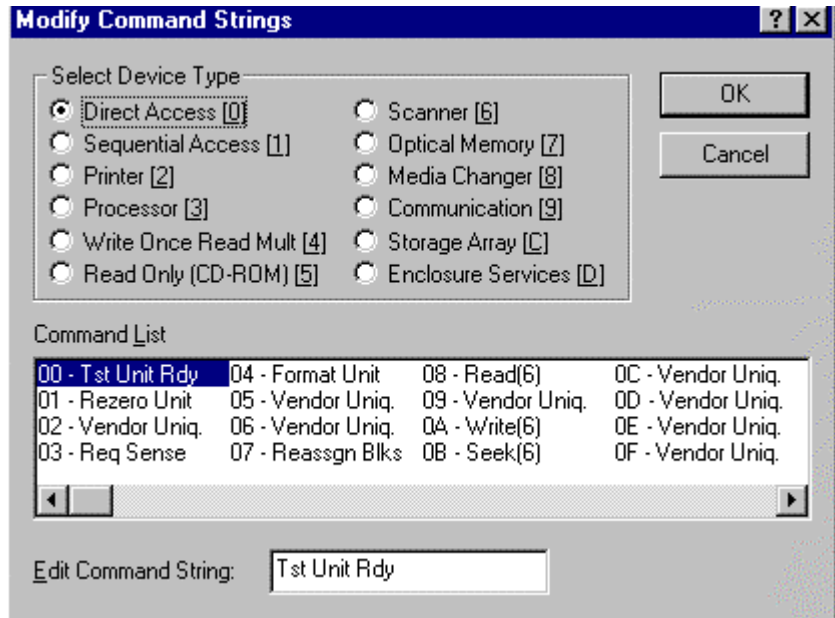

Figure 93

7.3.9 Define Read/Write Opcodes

Define Read/Write Opcodes defines the list of commands whose data phase transfer rates and counts are used to calculate the statistics in the Performance View, and the Burst Rate and Data Byte Counts in Phase and Command Views.

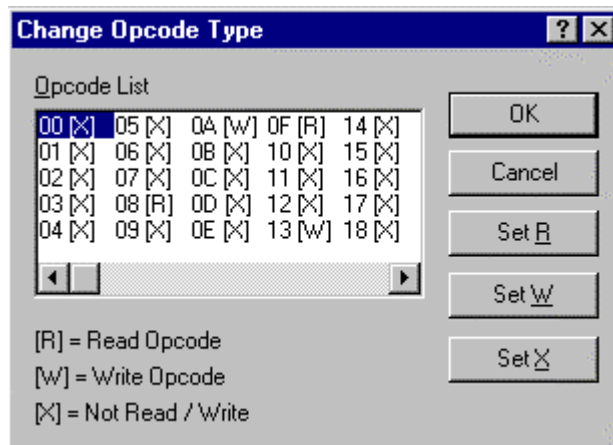

Figure 94

7.3.10 Timing Display Options

Timing Display Options sets the default conditions for the timing display.

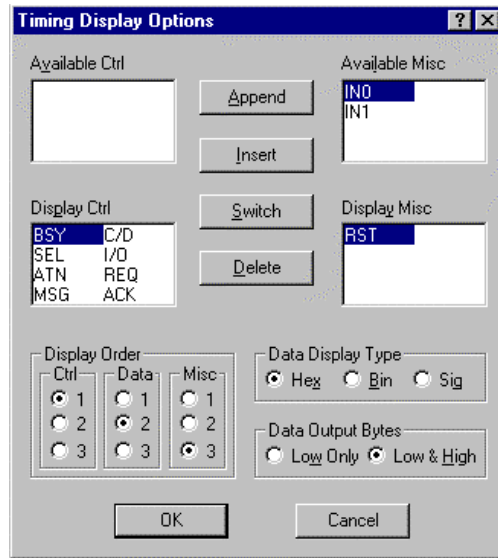

Figure 95

7.3.11 Popup Display Defaults

Popup Display Defaults sets the default conditions for each Phase, command, Timing and SCAM Timing Popup option.

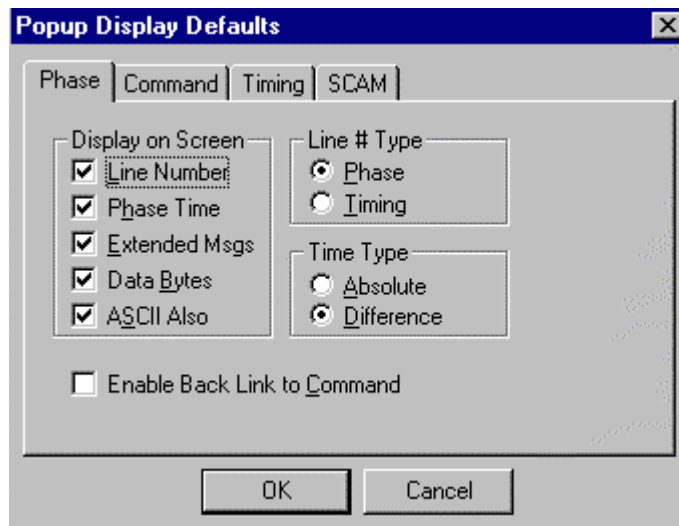

Figure 96

7.3.12 25/50 Lines

This command toggles the display between a twenty-five and fifty line high-density display. This option can also be toggled by typing **ALT-S**.

7.3.13 Capture Options

The Capture Options dialogs set the SCSI-View startup, Capture, Trigger and Data Phase Capture options. For the SV-8160 and SV-3000 different capture options and trigger dialogs are displayed depending upon capture type (Normal or Re-circulate, <**ALT-R**>). Normal type capture treats the SV-8160 and SV-3000 Pod buffer RAM like a large FIFO and transfers captured information to the PC during capture (similar to the SV-1620's operation.) Re-circulate type capture uses the Pod's hardware buffer as a circular buffer for maximum data rate capture.

Most Normal Type capture options also apply to the SV-1620 / SV-1600. Those options specific to the SV-8160 / SV-3000 are noted below.

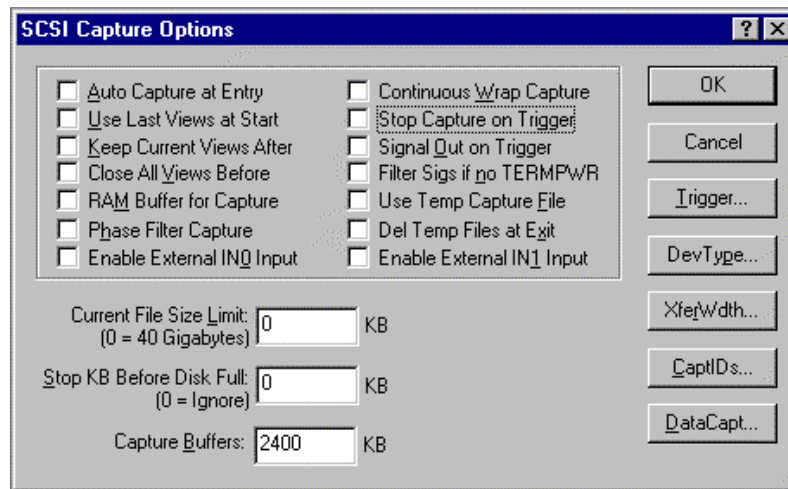

Figure 97 – Normal Type Capture Options

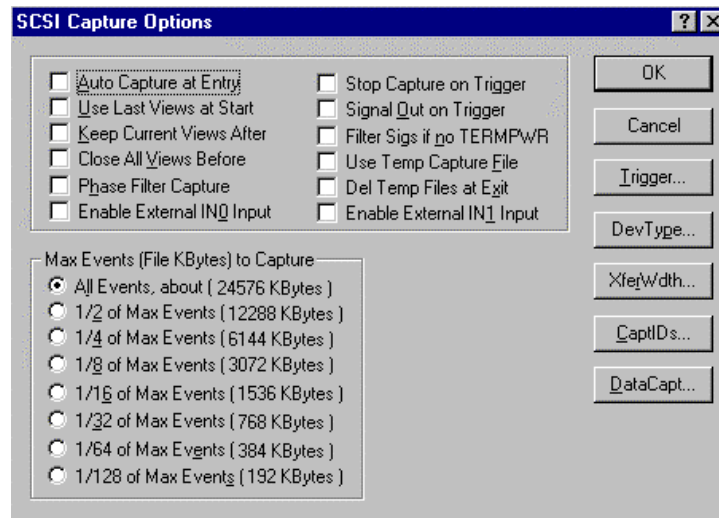

Figure 98 – Re-circulate Type Capture Options

7.3.13.1 Auto Capture at Entry (to SCSI-View)

If set, this enables SCSI-View to begin capture immediately after the SCSI-View program is started.

7.3.13.2 Signal Out on Trigger (SV-8160 / SV-3000)

If set, this enables an external signal output for triggering from the SV-8160 and SV-3000

7.3.13.3 Filter Sigs if no Power (SV-8160 / SV-3000 Re-circulate)

Temporarily pauses capture if Term-Power is removed from the SCSI bus. This option is useful for tracing through system power up/down cycles.

7.3.13.4 Use Last Views at Start (of Capture)

Remembers the previous Analysis Views that were used during the last capture and opens the same windows for each subsequent capture automatically.

7.3.13.5 Keep Current Views After (End of Capture)

Keeps the Current Analysis Views on screen after the end of a capture as File Analysis Views.

7.3.13.6 Close All Views Before (Starting Capture)

Closes all File Analysis Views prior to starting a new capture

7.3.13.7 RAM Buffer for Capture

Keeps all captured information in PC RAM instead of spooling to disk. Use the Continuous Wrap Capture option to create a circular buffer and use **Current File Size Limit** to set the buffer size. (Maximum of 32Mb.)

7.3.13.8 Continuous Wrap Capture (Circular Buffer)

Uses the capture .DAT file as a circular capture buffer of a size set by **Current File Size Limit** (see 7.3.13.13). This is useful when SCSI-View is used to trigger on infrequent SCSI operations and errors.

7.3.13.9 Stop Capture on Trigger

Enables the stopping of capture when the Trigger Dialog conditions are met.

7.3.13.10 Use Temp Capture File (\$\$TEMP.DAT)

Instead of asking for a new file name at the start of each new capture, SCSI-View will automatically capture to a file named **\$\$TEMP.DTT**. If the data captured to the temporary file needs to be saved, use **File, Edit File Session** or **File, DOS Prompt** to rename \$\$TEMP.DTT files prior the next capture.

7.3.13.11 Del Temp Files at Exit

Deletes \$\$TEMP.DTT, .IDX, .PFM and .CPF files upon exiting SCSI-View.

7.3.13.12 Output-Phase Begins With: REQ/ACK

(SV-1620 / SV-1600 only)

For SCSI output phases, selects whether the time-stamp for the phase is taken at the initial REQ or at the initial ACK. This option is present only for Phase mode captures. Timing mode captures will always time stamp output phases as starting on REQ.

7.3.13.13 Current File Size limit

Limits the size of the session capture file. This size should always be set to 3Mb or greater for continuous mode captures to provide for adequate buffering latency during capture file wrap around operations. Entries are in K bytes. An entry of **10000k** equals 10MB.

7.3.13.14 Stop KB Before Disk Full

When this limit is reached, the capture will automatically be stopped. Entries are in K bytes. An entry of **1000k** equals 1Mb.

7.3.13.15 Capture Buffers

Determines the maximum amount of PC memory that will be requested by SCSI-View as temporary buffers during capture. (The default value is 2.4Mb.) If the error message “Buffers Exhausted” is displayed during capture of very high command rate activity, and more memory is available on the host PC, this number can be increased to improve capture buffering performance. Use **the File, Hardware Information** dialog to determine how much buffer memory was actually granted SCSI-View by the operating system.

7.3.13.16 Trigger

The SV-8160 and SV-3000 provide different trigger conditions for Normal versus Re-circulate type captures. Normal Type Capture follows the same trigger dialog as has been used in the SV-1620. Re-circulate capture provides a subset of hardware only triggers implemented in the Pod FPGA hardware.

7.3.13.16.1 Normal Triggers (Also SV-1620 / SV-1600)

Up to 16 concurrent ‘ORed’ Trigger conditions ranging from SCSI bus conditions like RESET to specific CDB and Request Sense sequences can be used to stop capture. (SCSI-View’s Search Popup options roughly parallel its capture trigger options.)

Capture After Trigger sets the amount of capture after a trigger event.

For example: If the capture file size is set to 10000k (10MB) and Capture After Trigger is set to 1000k (1MB), 9MB will be saved before and 1MB will be saved after the trigger point.

Add adds the selected trigger to the trigger list. **Delete** removes a highlighted trigger from the trigger list.

Modify allows modification of a HEX byte trigger sequence on the trigger list. Highlight the trigger list sequence, modify it on the hex byte entry box and then press **Modify**.

Filter (Figure 100), ANDs a Target ID, LUN filter with the desired triggers.

Unfilt resets the filter trigger values to all Target IDs enabled for LUN zero and Initiator ID 7 enabled.

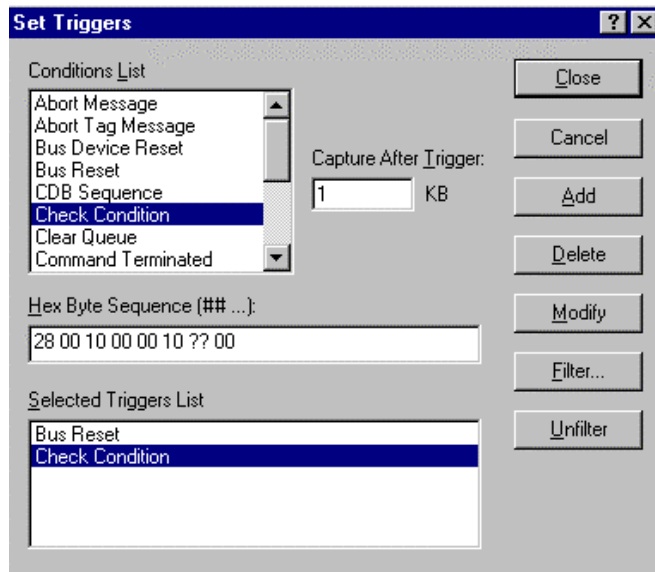
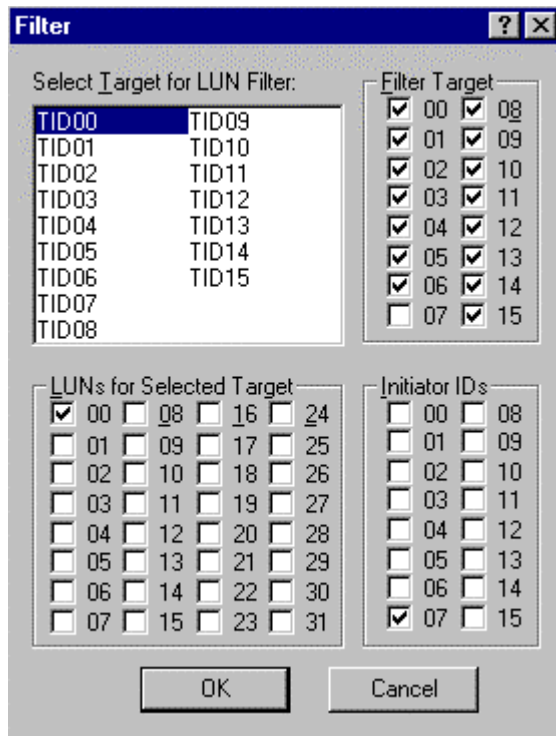

Figure 99

In addition to the Condition and Command trigger values available in the list box, individual HEX byte values can be triggered on by using the Msg Sequence, Status Byte, CDB Sequence, Data Phase Beg and Sub Sequence and Request Sense list items. Except for Status, these triggers can be for multi-byte HEX sequences. Up to 16 bytes may be entered for data phase sequences. **Data Beg-Seq** only searches from the beginning of a data phase while **Data Sub-Seq** slides the trigger sequence mask through the captured data phase data one byte at a time looking for a match. All multi-byte HEX sequences are entered separated by spaces. Individual nibble values can be wild-carded by entering the '?' character. Trailing bytes not entered for a multi byte sequence (such as for a CDB) will be automatically wild-carded.

Req Sense Sequence triggers on up to three request sense bytes, (The Sense Key (byte 1), the Additional Sense Code (Byte 12), and the Additional Sense Code Qualifier (byte 13). If the last one or two bytes of this three byte sequence are not specified they will be automatically wild carded. In addition, each byte can be wild carded on a nibble basis by typing a '?' for any digit. For Example: **To trigger on Unit Attention** in the sense key, enter: **?6** for the sequence. **To trigger on End of Data Detected** in the additional sense codes, enter: **?? 00 05**.



Trigger Filter Options
Figure 100

7.3.13.16.2 Re-circulate Triggers

Currently the SV-8160 and SV-3000 support four basic hardware triggers in Re-circulate type capture. Any combination of triggers may be selected at one time.

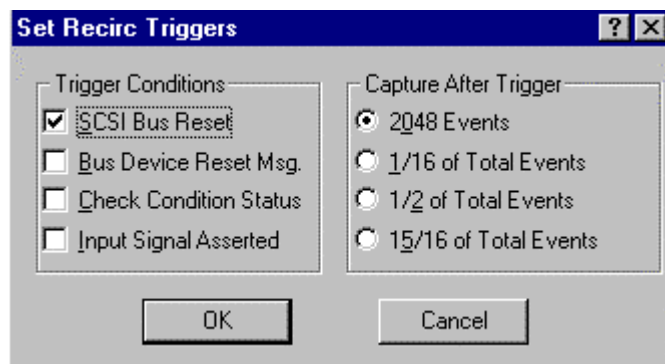

Figure 101

Additional hardware triggers (FPGA downloaded) will be added with subsequent SCSI-View software releases.

7.3.13.17 Device Type

Sets the default device types that SCSI-View will use to interpret and display commands. Setting an initial device type is useful when SCSI-View is activated after the initial device Inquiry commands that are present during a boot sequence, or when no data phase data capture is enabled. If SCSI-View subsequently sees an Inquiry command with captured data it will use the device type returned by the target for command byte interpretation.

Use the Popup command **Change Target Device Type** to change the device types in a .DTT file after capture is complete.

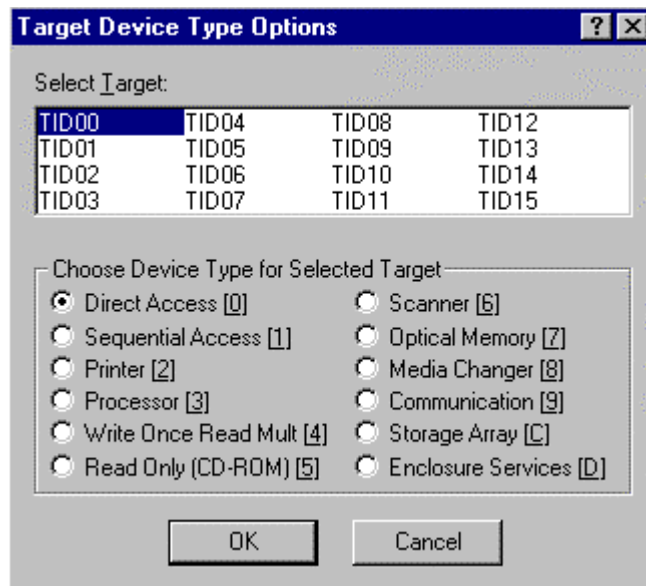

Figure 102

7.3.13.18 XferWdth

XferWdth sets the initial data width (wide or narrow) that SCSI-View will use to interpret data transfer operations for each target ID (**data counts, captured data displayed and calculated data rates**). SCSI-View will follow these values for displaying and counting data bytes until a different Wide/Narrow device negotiation takes place on the SCSI bus.

This is a display option and can also be changed at any time after a capture is complete. (See pop up options for Phase and Command Views.)

This option is useful when SCSI-View has been started after the initial target SCSI boot sequences that contain Wide-Narrow negotiations have completed.

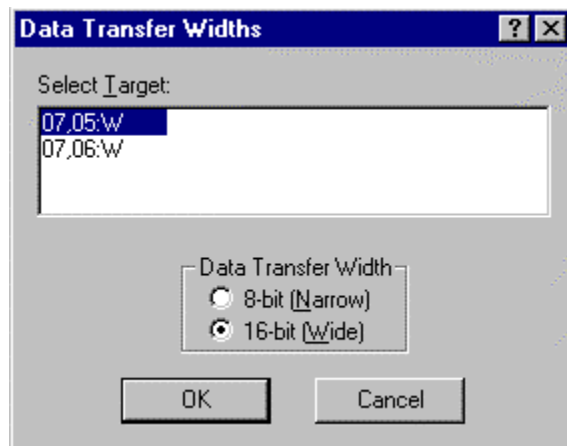

Figure 103

7.3.13.19 CaptIDs

(Front end ID nexus filtering – Phase mode only)

CaptIDs sets the Initiator/Target Nexus combinations for any SCSI capture. Initiator/Target ID pairs that are not both checked in this dialog will not store any activity to the .DTT or .DAT capture file.

This dialog is useful when a specific ID nexus is of interest and filtering out other device activity will reduce the capture file size and improve system performance.

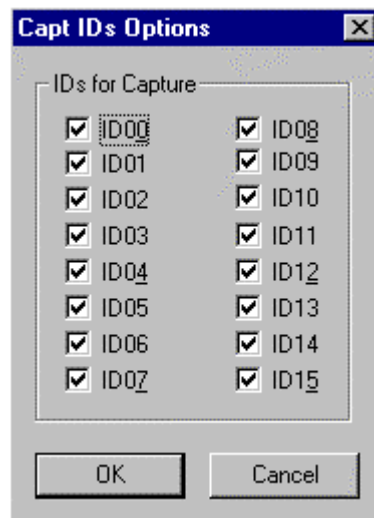
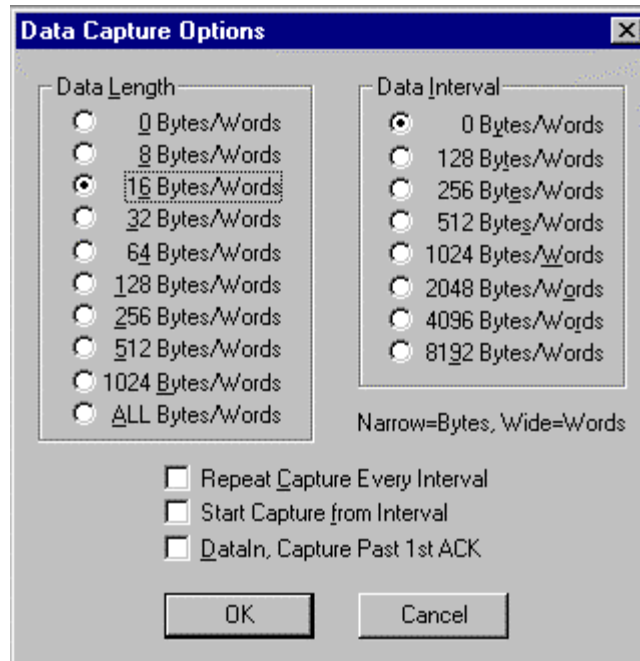

Figure 104

7.3.13.20 DataCapture Length)

Selects the target IDs and data phase length for R/W data phase captures. SCSI-View can capture up to 512 words on wide targets; 512 bytes on narrow targets. Use larger values here with caution. Capture values of 8 and 32 can be used on most levels of SCSI activity, but the 256 and 512 byte/word capture mode may cause the capture system to exhaust capture buffers while transferring to disk on very active targets. If this happens, reduce the capture size and restart the capture session. Also see section 7.3.13.15 on page 161 to increase capture buffer size. (The **RAM Buffer for Capture** option in the **Options, Capture Options** screen can also be used to optimize capture rate capability by using PC RAM as a circular buffer.) Figure 105 shows this dialog. The Data IDs section allows filtering out of various target IDs.



Data Capture Options

Figure 105.

In addition to a data length, a data interval can be set. **Checking Start Capture from Interval** offsets the capture by the interval amount. Checking **Repeat Capture Every Interval** causes the data window to repeat every 'N' bytes. This option can be used to capture a piece of each data block in a large data phase.

Data In, Capture Past first ACK forces the capture engine to capture data phase timing data up to the first ACK on **Data In Phases**. This guarantees the capture of first REQ to ACK times when the data capture length is set to zero.

In Phase Views of Timing Mode Captures involving intervals, the last line of the data display following the DataIn or DataOut Phase contains an indication of the amount of data bytes captured. The format for this display is shown below:

([+]SS:II[R] nn Bytes)

Fields in [] square brackets are optional.

+ means capture started from an interval boundary.

SS means capture size.

II means the interval size in bytes.

R means the capture was repeated on interval boundaries.

nn means the amount of bytes actually captured.

7.3.14 Normal / Recirculate Capt Type (SV-8160 / SV-3000)

Both the SV-8160 and SV-3000 can be switched between capture types by selecting this option or by pressing the <ALT-R> key. SCSI-View will indicate the current type of capture on the status line at the top of the screen to the right of the phrase **Capt Type**.

The SV-8160 (8 million events) and the SV-3000 (two million events) contain a **deep hardware RAM buffer** in the analyzer Pod. This buffer can be used either as a large FIFO buffer which is continually unloaded to PC RAM and disk files (Normal Capture Type), or as a stand alone circular buffer (Re-circulate Capture Type). Normal Type can capture very large data files (up to 2GB) of SCSI activity, but at a lower system throughput due to disk write and PCMCIA throughput limits. Re-circulate Type has the advantage that it can capture 100 percent of SCSI activity, including data phases to the two million event RAM buffer.

During Re-circulate capture no current analysis Views will be displayed.

Upon the completion of the capture session the event buffer contents are copied to disk and may be viewed with any of the **File** analysis Views.

Different Capture Options and Trigger dialogs are displayed for Normal and Re-circulate mode.

7.3.15 Phase / Timing Capture Mode (SV-1620 / SV-1600)

To toggle between Phase and Timing capture modes on the SV-1620 / SV-1600, select **Options, Phase / Timing Capture Mode**, or type **Alt-m**. SCSI-View will indicate the current mode of capture on the status line at the top of the screen to the right of the phrase Capt Type.

Phase capture mode is more efficient in its use of capture file resources due to its hardware SCSI phase recognition engine. Timing mode provides the highest level of capture detail at the expense of larger system throughput and file sizes (approximately 5 to 10 times that of Phase capture.)

When Timing capture mode is selected by the user, a timing capture engine is downloaded to the FPGA capture hardware in the SCSI-View POD. When Phase capture is selected, the Phase recognition and capture engine is downloaded to the FPGA hardware.

Timing mode capture files use the suffix .DTT. Phase mode capture files (SV-1620, SV-1600, SV-8020 only) use the suffix .DAT.

Use of the Timing Mode requires the Timing Option for the SV-1620 / SV-1600.

7.4 ANALYSIS

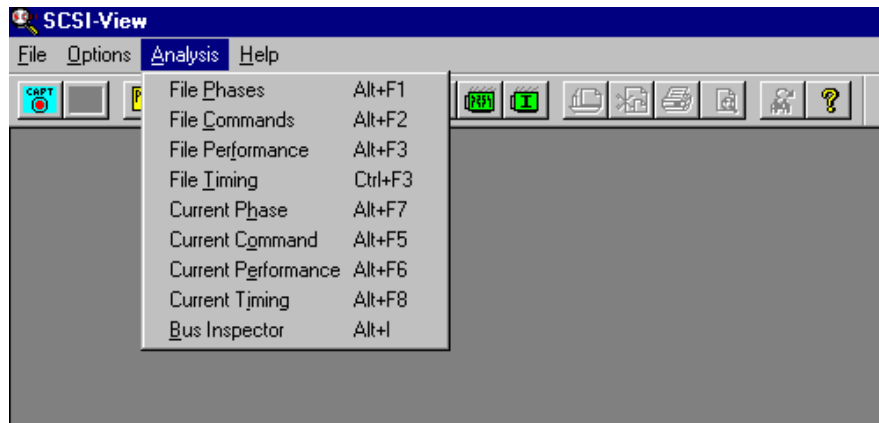

Figure 106

The analysis menu forms the heart of SCSI-View's feature set. From this menu users can choose multiple SCSI Timing, Phase, Command, Performance and Bus Inspector Views for analysis on screen.

FILE Analysis Views present previous captured information files. **Current mode Analysis Views** present Views of currently capturing SCSI information. In current mode, data scrolls down each analysis View as SCSI activity occurs.

7.4.1 Phase and Command Views

The Phase and Command protocol Views display current or previously captured SCSI protocol activity. Multiple View windows can be open at one time. For example, multiple protocol windows can be used to compare current and previous SCSI activity, to display current SCSI activity filtered for different SCSI ID and LUN values and to display SCSI activity at different levels of detail. Figure 107 shows a Command View and a linked Phase View of the same file. (A detailed description of each Command and Phase Protocol View item is provided in section 6.1 on page 69).

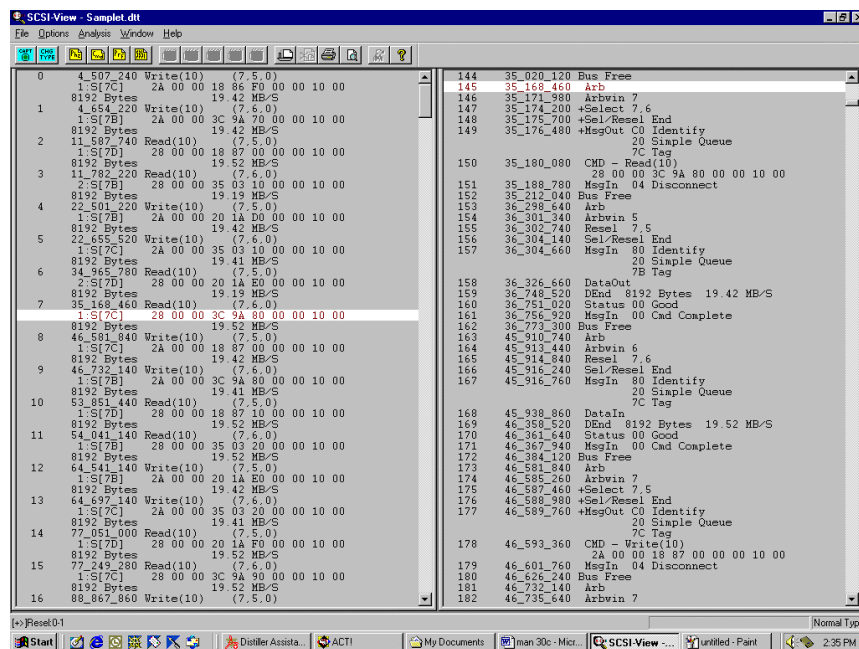

Figure 107

7.4.1.1 Current Phases

Opens a Protocol window for the current capture session file. SCSI activity is displayed at the Phase level. This is SCSI-View's highest level of protocol detail. SCSI operations are shown in detailed form from their initial ARB phase through the following BUS FREE phase. Each SCSI-Phase is shown time stamped (either elapsed time or difference time spent in that phase), and with its data bytes (if appropriate). **Note:** Current Phases is available only in the unfiltered by ID mode.

7.4.1.2 Current Commands

Opens a protocol window for the current capture session file. SCSI activity is displayed at the Command level, which condenses SCSI activity into command

entries. A command entry is generated for each completed command operation, (such as READ, INQUIRY, MODE SEL, etc.), along with time stamps covering the beginning and ending times for the group of SCSI phases making up that command. This display level reduces the amount of display overhead significantly by removing repetitive the overhead operations such as ARB, SEL from display. Note that commands that span multiple disconnects will not be displayed until they are complete. The resultant command entry will note the beginning time for the first phase of the initial disconnected phase group, and the ending time of the last re-connected phase group.

Note: Only one Current Command View may be active at any time. In addition, the Current Command View is available only in the unfiltered by ID mode.

Current Command is not available in Continuous Capture mode. (This is due to the difficulty determining the command completion status, time etc. for every command when a file has wrapped around upon itself.)

7.4.1.3 File Phases

File Phases opens a protocol window for a previous capture session file. SCSI activity is displayed at the Phase level. This is SCSI-View's highest level of protocol detail. SCSI operations are shown in detailed form from their initial ARB phase through the following BUS FREE phase. Each SCSI-Phase is shown time stamped, (either actual time or time spent in that phase), and with its data bytes, (if appropriate).

This View can be filtered by ID and LUN, and its start and stop analysis points can be set by selecting start and stop markers in the file open dialog.

When any File Phases View is filtered for the first time on a particular capture file, or when a new filter criteria is specified, SCSI-View also begins building a navigation index file for that capture file. The status line will indicate this with the 'Building Index' message. For very long capture files this may take some time, but the file can be viewed and navigated up to the point of index completion while the build is in progress. Subsequent openings of the Phase View for this file will not require a new index build. (**CTRL BREAK** can halt this indexing operation). Index files have the extension '.IDX' and the same name as the capture file. When deleting capture files, also remember to delete the corresponding .IDX, .PFM, and .CPF files. (If a file is renamed to a name that has existing .IDX, .PFM and .CPF files, these files will be automatically deleted).

7.4.1.4 File Commands

Opens a protocol window for a previous capture session file. SCSI activity is displayed at the Command level, which condenses SCSI activity into command entries. A command entry is generated for each completed command operation, (such as READ, INQUIRY, MODE SEL, etc.), along with time stamps covering the beginning and ending times for the group of SCSI phases making up that command. This display level reduces the amount of display overhead significantly by removing repetitive the overhead operations such as ARB, SEL from display. Note that commands that span multiple disconnects will not be displayed until they are complete. The resultant command entry will note the beginning time for the first phase of the initial disconnected phase group, and the ending time of the last re-connected phase group.

This View can be filtered by ID and LUN, and its start and stop analysis points can be set by selecting start and stop markers in the file open dialog.

When any File Command View is started for the first time on a particular capture file, or when a new filter criteria is specified, SCSI-View also begins building a navigation index file for that capture file. The status line will indicate this with the 'Building Index' message. For very long capture files this may take some time, but the file can be viewed and navigated up to the point of index completion while the build is in progress. Subsequent openings of the Command View for this file will not require a new index build. Index files have the extension '.IDX' and the same name as the capture file. When deleting capture files, also remember to delete the corresponding '.IDX' files.

7.4.2 Performance

The Performance View, (Figure 108), is used to display performance parameters for current or previously captured SCSI activity files. Multiple performance View windows can be open at one time. For example, multiple windows can be used to compare current and previous SCSI performance values, or to display current SCSI performance filtered for different SCSI ID and LUN values and to analyze tagged queue performance. (A detailed description of each Performance analysis item is provided in section 1.1 on page 89).

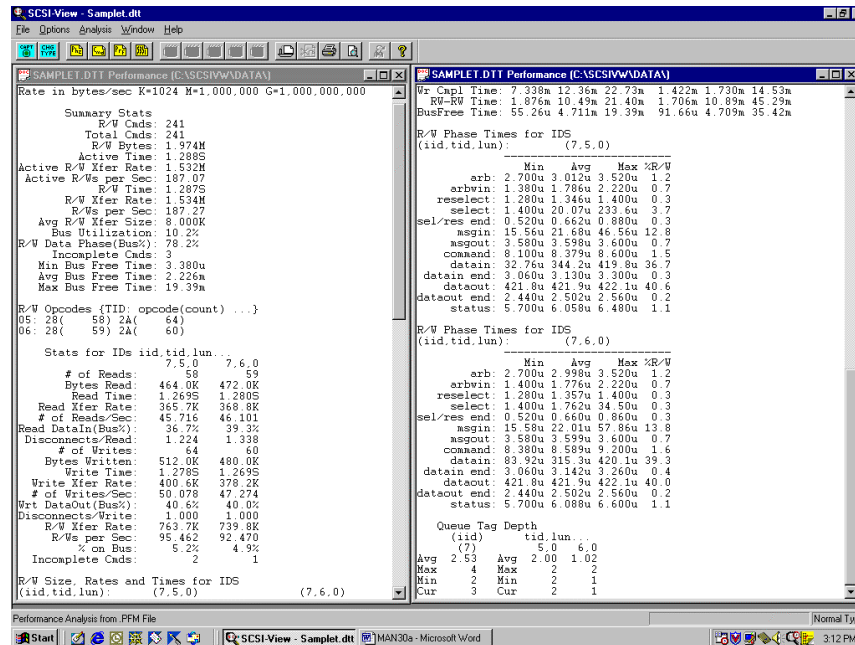

Figure 108

7.4.2.1 Current Performance

Opens a performance window for the Current SCSI capture file.

Note: Current Performance is available only in the unfiltered by ID mode.

Performance calculated while capturing in continuous capture mode will keep performance statistics for the complete capture session, including events prior to the file wrap point, in a .CPF file. The .CPF file will be used automatically to display the continuous capture performance statistics when subsequent **File, Performance Views** are opened. If command rate activity is occurring at a rate faster than can performance statistics can be calculated prior to a continuous capture file wrap, a warning message will be displayed and statistics will only be calculated for the data actually in the continuous capture file.

Performance calculated for a regular non-continuous capture file will be stored in a .PFM file. Subsequent File, Performance Views of the .DAT file will use the results stored in the .PFM file to save recalculation time.

7.4.2.2 File Performance

Opens a performance window for any previous SCSI capture file. This View can be filtered by ID and LUN, and its start and stop analysis points can be set by selecting start and stop markers in the file open dialog.

7.4.3 Bus Inspector

The Bus Inspector View, Figure 109, can only be activated during a current capture. (**Analysis, Curr Bus Inspector**) This View shows the status of each SCSI hardware line sampled as often as possible (Typically every 200-500ms.). Active lines are denoted with a **X**. This View is most useful for determining the status of a hung SCSI bus and stuck SCSI control lines and data bits. On low to moderate activity busses, the Bus Inspector may mostly display 'Bus Free.' This is due to the fact that low to moderate busses are most likely to be in the Bus Free state when the Bus Inspector samples the bus).

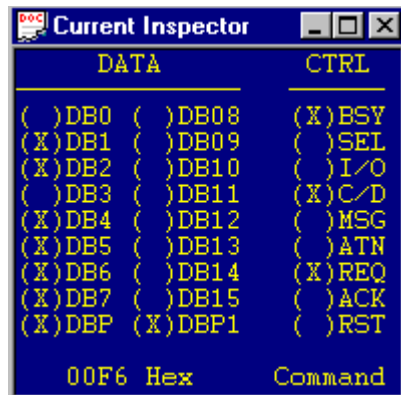

Figure 109

7.5 WINDOW

Window	Help
<u>C</u> lose	Ctrl+F4
Clo <u>s</u> e <u>A</u> ll	Ctrl+F8
<u>S</u> ize	Ctrl+F5
<u>M</u> ove	Shift+Ctrl+F5
<u>Z</u> oom	F5
<u>N</u> ext	Ctrl+F6
<u>P</u> revious	Shift+Ctrl+F6
Cascad <u>e</u>	
<u>T</u> ile	

Figure 110

7.5.1 Next

Selects and brings to the top the next window in a rotating sequence of all windows on screen.

7.5.2 Zoom

Zooms the currently selected window to Full Screen. Selecting Zoom again will return the window to its original size.

7.5.3 Close

Closes the current focused window.

7.5.4 Close All

Closes all open windows.

7.5.5 Size

Resizes the active window using the shift and cursor keys.

To change the size of a currently focused window, select **Window, Size** (CTRL F5), and press SHIFT while using the arrow keys to move the lower right window corner. Press Enter to exit this mode.

7.5.6 Move

Moves the active window using the shift and cursor keys.

To change the location of a currently focused window, select **Window, Size** (CTRL F5), and use the arrow keys to move the window location. Press Enter to exit this mode.

7.5.7 Cascade

Displays all windows in an overlapped, cascading display.

7.5.8 Tile

Displays all windows on screen at the same time. Windows are sized as needed to fit on the desktop.

7.6 HELP

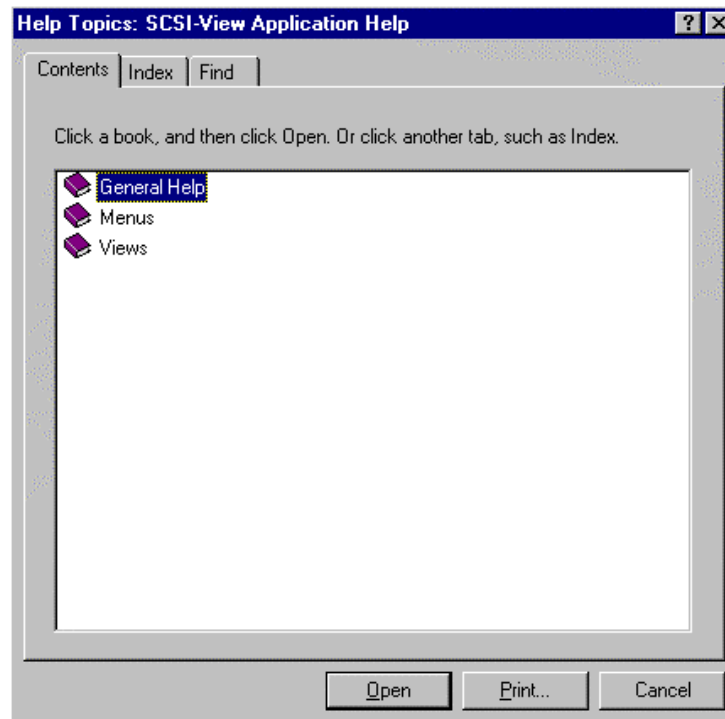

Figure 111

SCSI-View has extensive on line help, which is available at any point in its operation. Help includes complete descriptions of every Phase, Command and Performance View display item and 'how to use' instructions for each feature. **Press F1 for a complete help description of the current displayed analysis View or menu item.** For a more structured on line description see the **Help, Index** menu item for a complete hypertext linked description of how to use SCSI-View.

7.6.1 Index

Displays an index for Help. Double click on any highlighted item to jump to that help entry.

7.6.2 Getting Started

Provides a quick description of setting up and starting SCSI-View for immediate use.

7.6.3 Cursor Movement Keys

Lists the keystrokes that aid moving around SCSI-View windows.

7.6.3.1 SCSI-View Cursor Movement Key Descriptions

UP Arrow	Moves up one line
DOWN Arrow	Moves down one line
<SHFT>UP Arrow	Moves up one item (full command or phase)
<SHFT>DOWN Arrow	Moves down one item
TAB	Moves N commands or phases down
<SHFT>TAB	Moves N commands or phases up (N is set in Options, Display) (TAB and <SH> TAB move forward and back one field in Dialogs)
<CTRL> HOME	Moves to the top of the viewed file
<CTRL> END	Moves to the end of the viewed file
HOME	Moves View window to the left side
END	Moves View window to the right side

7.6.4 Function & Hot Keys

Provides a listing of all Function and special hot key definitions.

7.6.4.1 SCSI-View Function and Hot Key Descriptions

F1	Help (Context Sensitive)
F2	Popup Menu Commands (Command or Phase View - same as the right mouse button.)
F3	Display Setup Dialog
F4	Capture Options Dialog
F5	Zoom Window (Full Size)
F6	Next Window
F7	Save Current File and resume
F8	Information Box
F9	Print a File
<SHFT> F1	Create a Linked Phase View (From Command View only.)

<SHFT> F2	Go To Event / Command Number
<SHFT> F3	Find SCSI Operation
<SHFT> F4	Find Phase Time (Phase View only)
<SHFT> F5	Find Burst Rates (Phase View only)
<SHFT> F6	Find Command (Command View only)
<SHFT> F7	Markers (Display and define markers)
<ALT> F1	Open File Phase View
<ALT> F2	Open File Command View
<ALT> F3	Open File Performance View
<ALT> F4	Open Current Phase View
<ALT> F5	Open Current Command View
<ALT> F6	Open Current Performance View
ESC	Escape from any dialog; removes the highlight from a line.
ENTER	Highlights the middle line of the focused View if none was previously highlighted. If a line was previously highlighted and then turned off, that line will be highlighted. Typing -ENTER again will toggle the highlight on and off.
<ALT> a	Open Analysis menu
<ALT> c	Toggle Capture on/off
<ALT> f	Open File menu
<ALT> h	Open Help Menu
<ALT> k	Kill Print Queue
<ALT> m	Toggle Capture Mode
<ALT> n	Find Next Search Item
<ALT> o	Open Options Menu
<ALT> p	Print (active View)
<ALT> s	25/50 Line Display

7.6.5 Mouse Functions

Lists all Mouse Functions

7.6.5.1 SCSI-View Mouse Functions

- **Clicking the LEFT MOUSE BUTTON** in a non-focused window selects that window.
- **Clicking the LEFT MOUSE BUTTON** on a line in a focused window will highlight that line. If the line was already highlighted, this will un-highlight it. Highlighting a line in a Current View will freeze screen updates until the highlight is released.
- **Clicking the LEFT MOUSE BUTTON** on the small square bracketed icon in the upper left corner of any window will close that window.
- **Clicking the RIGHT MOUSE BUTTON** in a Command or Phase View window will select that window and cause the Popup Operations menu to appear. Clicking the Right Mouse Button again, or pressing ESC, will close the Popup menu. (Clicking the Right Mouse Button in a Performance View has no effect.)
- **Double Clicking the LEFT MOUSE BUTTON** in a Command View will open a linked Phase View. If no line was highlighted in the Command View, the line at the center of the View will be highlighted (All movement in the Command View will cause the Phase View to move to the same point.). Double clicking the left mouse button again in the Command View will close the linked Phase View.

7.6.6 Technical Support

Provides the Technical Support Phone and Fax numbers at Verisys. Please call us if you experience any problems with SCSI-View, or if you would like to suggest additional features or improvements to the product.

Our Technical Support Group is available Monday through Friday (except U.S. holidays), 9:00am to 5:00pm, Pacific Coast Time (California, USA).

Verisys Technical Support can be reached at:

Phone: (831) 662-7900

FAX: (831) 662-7910

Web: <http://www.verisys.com>

(The web page also has links for downloading current S/W. You must be in support to receive the latest SCSI-View software and features.)

Email: svsupport@verisys.com

7.6.7 About

Displays the current release revision and date of the SCSI-View Hardware and Software.

7.7 Miscellaneous Dialogs

7.7.1 Open File Dialog

The Open File dialog, Figure 112, is used for opening File Phase, Command and Performance Views. The desired session file can be typed into the Session File box, or it can be chosen by clicking on the desired list box file with the left mouse button. Double left clicking on a file name will immediately open that file.

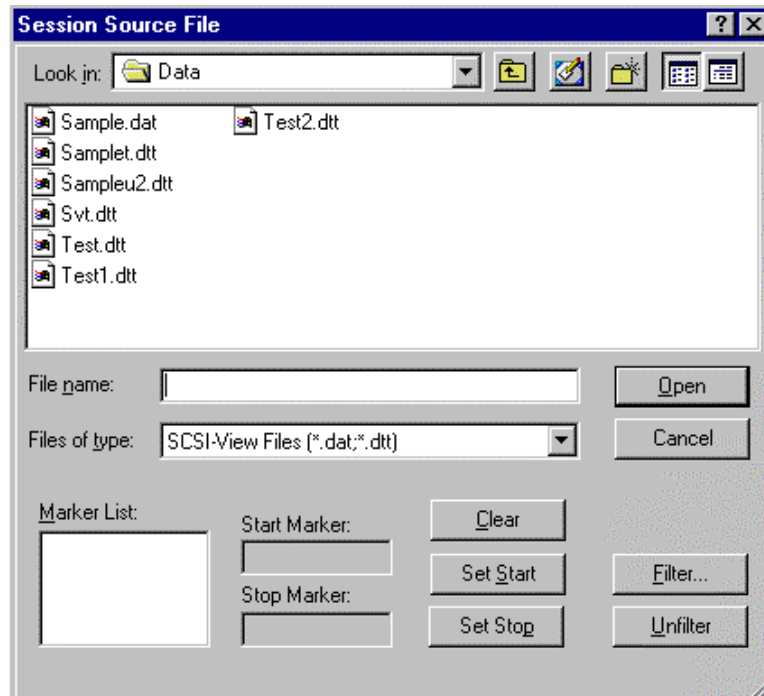

Figure 112

File Phase, Command and Performance analyses can also be filtered by ID and LUN to remove unwanted devices. Click on the Filter button to select which devices you wish to include in the analysis. See section 5.7, Filtering Views for Specific Device ID's and LUN's, on page 64, for a description of filter selection.

Start and Stop points for any analysis can also be chosen from the list of markers for each file. (Markers are set through the Marker Popup dialog while in Phase View for the file.) To chose a start marker, click on the desired marker in the lower left list box and then click on the START button. The marker name will then appear in the Start Marker box. Repeat this operation using the STOP button if you also wish to set a stop point for analysis.

Start and Stop markers are used to do the following:

- Limit Display and Printing to a desired range for Command and Phase Views. (The File, Print dialog always prints the same range as the current active View.)

Limit Performance analysis to a range of phases. This is useful to isolate performance problems to a region of activity, and to avoid operations that may distort a performance analysis, such as an initial power on SCSI bus scan.

8 SCSI-View Specifications

All SCSI-View analyzers use an FPGA based hardware capture engine and include SCSI-View software.

SCSI-View software and hardware is Year 2000 compliant.

8.1 SV-8160

Wide, Ultra-3 / LVD (160 MB/Sec.), Single Ended and HVD interfaces

4ns resolution, all signals

8 / 16 bit, Single Ended, LVD / HVD

Eight Million Event H/W Buffer in SCSI-View Pod. (Full data phase analysis.)

Also capture to PC RAM and to Disk Files (42GB).

LVD / SE: active switchable termination

HVD: passive switchable termination

External Signal In (2); Trigger Out (1) lines.

PCMCIA card (Type 2)

68 pin connector (50 pin adapters available)

Powered from PCMCIA or from external power module (supplied).

SCSI-View POD can be run in stand-alone capture (without laptop PC), when powered from an external power module.

.01% clock accuracy (100 PPM)

Windows 95/98, Windows NT and Windows 2000 software

Context sensitive on-line help

Print any Protocol, Timing or Performance View (between markers), to a file or directly to a printer.

Extract any portion of a captured file for later analysis (either ASCII print, or binary file).

POD Dimensions: 7.5" (l) x 4.0" (w) x 1.12" (h)

8.2 SV-3000

Wide, Ultra-2 / LVD (80 MB/Sec.), Single Ended and HVD interfaces

5ns resolution (REQ/ACK)

8 / 16 bit, Single Ended, LVD (HVD with the optional AD-200 adapter.)

Two Million Event H/W Buffer in SCSI-View Pod. (Full data phase analysis.)

Also capture to PC RAM and to Disk Files (42GB).

Passive termination for differential (HVD/LVD); Active termination for Single ended.

External Signal In (2); Trigger Out (1) lines.

Input Hysteresis: 200mv

PCMCIA card (Type 2)

68 pin connector (50 pin adapters available)

Powered from PCMCIA or from external power module (supplied).

SCSI-View POD can be run in stand-alone capture (without laptop PC), when powered from an external power module.

.01% clock accuracy (100 PPM)

Windows 95/98, Windows NT and Windows 2000 software

Context sensitive on-line help

Print any Protocol, Timing or Performance View (between markers), to a file or directly to a printer.

Extract any portion of a captured file for later analysis (either ASCII print, or binary file).

POD Dimensions: 7.5" (l) x 4.0" (w) x 1.12" (h)

8.3 SV-1620

Wide, ULTRA SCSI (40MB/Sec.)

10ns resolution (REQ/ACK)

8 / 16 bit, Single Ended or Differential

Passive differential termination; Active termination for single ended (S/W enabled)

Phase, Command, Timing, Performance and Bus Inspector Views

Input Hysteresis: 200mv

PCMCIA interface card

.01% clock accuracy (100 PPM)

Windows 95/98, Windows NT and Windows 2000 software

68 pin high density connector (adapter to 50 pin available)

PCMCIA based SCSI analyzer

POD Dimensions: 5.75" (l) x 3.6" (w) x 0.8" (h)

8.4 SV-1600

ISA bus card version of the SV-1620 analyzer. The SV-1600 same features as the SV-1620, but uses DOS version of SCSI-View S/W.

10ns resolution (REQ/ACK)
Wide, ULTRA SCSI (40MB/Sec.)
8 / 16 bit, Single Ended or Differential
Passive differential termination; Active termination for single ended (S/W enabled)
Phase, Command and Performance and Bus Inspector Views
Input Hysteresis: 200mv
.01% clock accuracy (100 PPM)
68 pin high density connector (adapter to 50 pin available)

8.5 Timing Option

Timing Display Option for SV-1600
Software Option - no additional hardware required (Downloads new capture engine hardware to FPGA)
10ns sample clock on REQ-ACK, event driven capture
.01% clock accuracy (100 PPM)
Linked Phase and Timing Views on screen

8.6 SV-8020

FAST SCSI 1,2 & 3 (20MB/Sec.)
DOS based S/W
8 bit, Single Ended
Active termination (S/W enabled)
Phase, Command and Performance and Bus Inspector Views
PCMCIA card
.01% clock accuracy (100 PPM)
50 pin high density connector
PCMCIA based SCSI analyzer

Dimensions

5.75" (l) x 3.6" (w) x 0.8" (h) POD

8.7 Software Analysis Features - All Analyzers

Context sensitive on-line help
Simultaneous operation of all SCSI View features.
Print any Timing, Phase, Command or Performance View (between markers), to a file or to ASCII disk file
Extract any portion of a captured file for later analysis (either ASCII print, or binary .DAT file)
Runs simultaneously with other Windows applications (including SCSI stimulator programs; SV-HostEm.)

8.7.1 Protocol Analysis:

Protocol Capture can be filtered by ID both on capture (.DAT files only) and while viewing.

Current SCSI activity can be viewed next to previous SCSI captures.

Protocol Capture Time Stamp Resolution:

4ns (SV-8160), 5ns (SV-3000), 10ns (SV-1620, SV-1600); 30ns (SV-8020, SV-8000)

Linked Command, Phase and Timing Views

Displays and decodes results of synchronous and wide - narrow negotiations.

Activity is displayed in real time, and is stored to disk for very deep capture sessions.

Data Capture (0-all bytes per data phase - adjustable)

Data Capture Filter IDs are user selectable

Capture to a fixed size file, or continuously to a circular file buffer or RAM buffer. (Also to a 2M event hardware RAM buffer on the SV-3000.)

8.7.1.1 Command View:

Command type and CDB

Time stamp: Absolute, Completion, Difference or Active Time

Command completion status: Complete, Incomplete, Aborted, Terminated, Reset

Number of reconnects per command

Tag byte value

Number of bytes and burst rate

8.7.1.2 Phase View:

Phase type and CDB

Time Stamp (Absolute or Difference time)

Message / Status bytes: Decoded text values

Number of bytes and burst rate

Captured data phase bytes are displayed

ATN presence at the beginning of each phase

8.7.1.3 Search Captured Protocol Files for:

Phase Time for a each phase, (<, >)

Burst Data Rate, (<, >)

Command Completion Time (<, >)

Incomplete Commands

SCAM Select

SCSI CDB sequences with wildcards

Message sequences with wildcards

Data Phase Sequences with wildcards (up to 16 bytes)

Status byte

Sync. Negotiation

Wide Negotiation

Request Sense Bytes

Terminated, Busy, Incomplete or Checked Commands

All searches can be qualified by Initiator ID, Target ID and LUN.

'GoTo' SCSI event and command line numbers

'GoTo' user defined markers

8.7.1.4 Protocol Capture Trigger Conditions:

CDB Sequences (with wildcards)

Message Sequences (with wildcards)

Status Byte

Data Phase Bytes (up to 16 with wildcards)

Request Sense Byte Values

Unexpected Bus Free

Abort Message

Bus Device Reset

Bus Reset

Check Condition

Clear Queue

Command Terminated

Queue Full Status

Unexpected Bus Free

16 trigger conditions may be or'd together

Triggers may be qualified by ID and LUN

8.7.2 Performance Analysis: (for each SCSI ID, LUN)

Number of Read / Write Commands

Number of Bytes Read / Written

Active time on Bus, Bus Utilization %

Data Phase as a % of Active Bus Time

R/W Sizes (Min, Avg., Max)

Number of Incomplete Commands

Number of Disconnects per R/W Bus Free Time (Min, Avg., Max)

Data Burst, Throughput and Connect Rates (min, max, average)

R/W to R/W time (Min, Avg., Max)

R/W command completion time (Min, Avg., Max)

Time spent in each SCSI phase (Min, Avg., Max, %)

Tagged Queuing depth (Min, Avg., Max, Current)

Analyze performance in real time on active systems, or on captured files.

Compare analyses side by side.

Analyze performance between user defined markers.

8.7.3 SCSI Bus Inspector View

Displays the state of all SCSI lines

Ideal for inspecting a hung busses

Updates in real time (approx. every 300ms.)

8.8 SV-ISA

PCMCIA to ISA bus adapter that allows the SV-8160, SV-3000, SV-1620 and SV-8020 to be used on desktop PCs.

8.9 SV-HostEm

Tests, diagnoses, exercises and programs any SCSI device, including disk, tape and optical devices.

Built in device tests, commands and user defined scripting.

Sets mode page values, downloads firmware, changes block size and much more.

Multi-drive capability automates test / set-up procedures and provides for use on up to 15 drives simultaneously.

Supports multiple ASPI compliant SCSI controllers.

Multi-tasks with SCSI-View on the same PC. (Stimulate and analyze SCSI systems from the same notebook PC.)

8.10 SCSI-View Reader

Software only version of SCSI-View. Allows viewing and analysis of .DTT and .DAT files without presence SCSI-View H/W.

8.11 SV-Interface

A C++ interface program that allows users to write their own analysis programs for SCSI-View captured .DAT files. SV-Interface returns 'next event' SCSI information along with corresponding timestamps and associated data bytes each time it is called by user code.

SV-Interface requires advanced C++ programming knowledge.

9 Verisys Warranty and Repair Policy

Statement of Verisys Limited Warranty:

- Verisys warrants that each analyzer is free from defects in materials and workmanship for one (1) year from the date of purchase.
- The Warranty does not cover damage or failure connected with misuse, abuse, accident, or any modifications made to the analyzer by any party other than Verisys. Please note that damage resulting from application of power sources that exceed 5.0 volts is explicitly not covered under this warranty.

Warranty and Repair Service:

- Please contact **Verisys** at **(831) 662-7900** for warranty and repair service information.
- Repairs that fall outside of the terms of warranty will be made by Verisys after customer provides a purchase order or equivalent against a cost of repair provided by Verisys.
- Parts for warranty or repair service may only be returned with the prior approval of Verisys and *must have a Verisys RMA number assigned prior to return.*
- Upon obtaining return approval and an RMA number, please ship items to:

Verisys, Inc.
Attn: RMA#_____
335-H Spreckels Dr.
Aptos, CA 95003

- Shipping costs incurred for returning items to Verisys and any loss or damage that may occur as a result of shipping those items are the sole responsibility of the purchaser. Following completion of warranty or repair service, Verisys will pay shipping costs for returning items to purchaser.
- Note that when a type of service involves the exchange of an analyzer or a part thereof, the item which Verisys replaces becomes the property of Verisys and the replacement analyzer or part thereof becomes the purchaser's. The replacement item will be at least functionally equivalent to the item replaced.